

OC8000iF 19-25

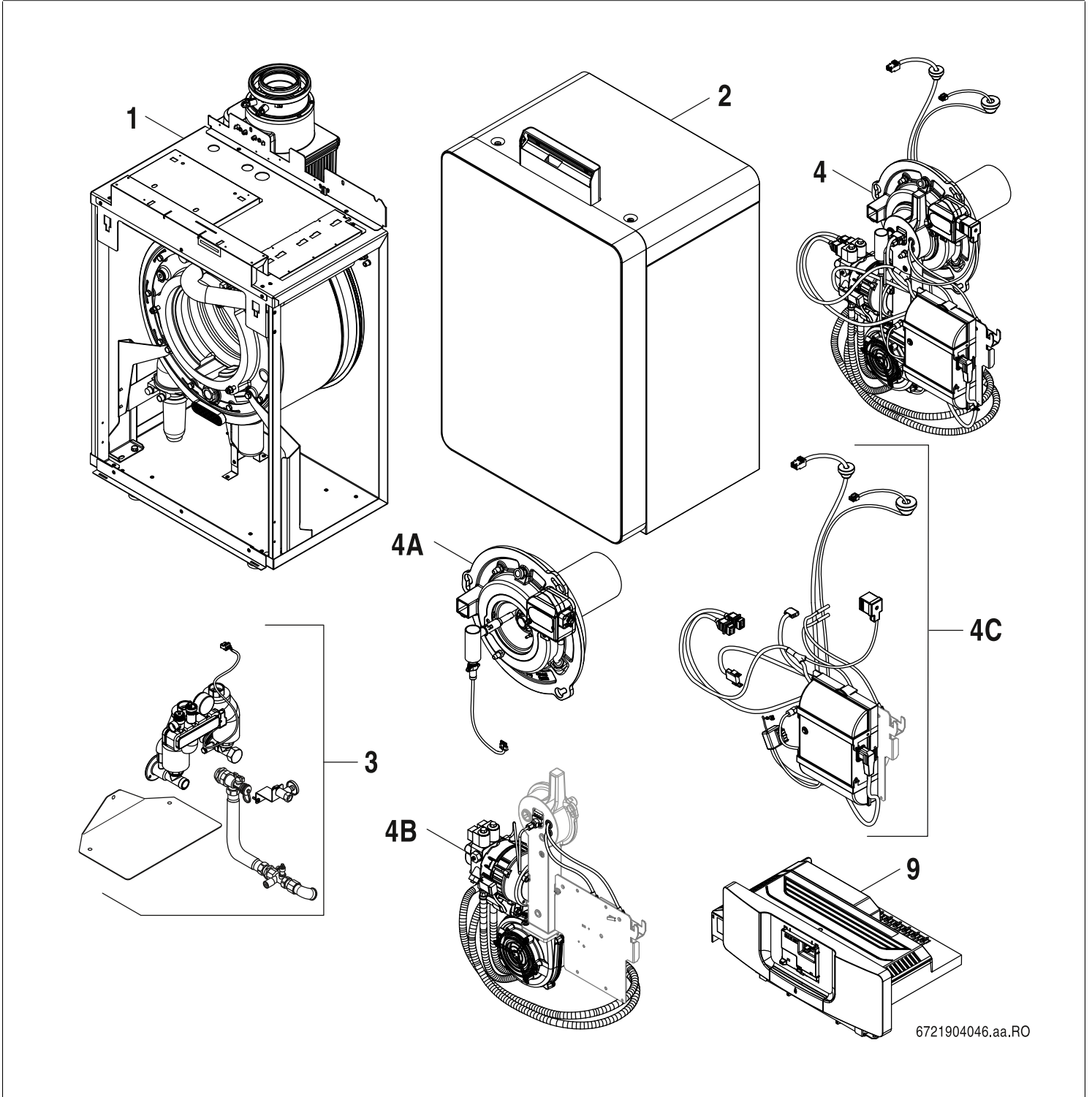

6721904046.aa.RO

[de] Wichtige Hinweise zur Installation/Montage

Die Installation/Montage muss durch eine für die Arbeiten zugelassene Fachkraft unter Beachtung der geltenden Vorschriften erfolgen.

[en] Important notes on installation/assembly

The installation/assembly must be carried out by a professional who is authorised to do the work, and with due regard to the relevant regulations.

[fr] Instructions importantes pour l'installation/le montage

L'installation/le montage doit être effectué(e) par un spécialiste qualifié pour les opérations concernées et dans le respect des prescriptions applicables.

[bg] Важни указания във връзка с инсталацията/монтажа

Инсталацията/монтажът трябва да се извършва от лицензиран за работите специалист в съответствие с приложимите разпоредби.

[cs] Důležité pokyny k instalaci/montáži

Instalaci/montáž musí při dodržení platných předpisů provést odborný pracovník s příslušným oprávněním pro tyto práce.

[da] Vigtige anvisninger til installationen/monteringen

Installationen/monteringen skal foretages af en godkendt installatør under overholdelse af de gældende forskrifter.

[el] Σημαντικές υποδείξεις για την εγκατάσταση/συναρμολόγηση
Η εγκατάσταση/συναρμολόγηση πρέπει να πραγματοποιείται από εξουσιοδοτημένο για τις εργασίες αυτές τεχνικό προσωπικό, το οποίο θα πρέπει να φροντίζει ώστε να τηρούνται οι ισχύουσες διατάξεις.

[es] Indicaciones importantes para instalación/montaje

La instalación/el montaje lo debe realizar personal especializado autorizado para los trabajos, respetando las prescripciones vigentes.

[et] Olulised juhised paigaldamiseks/montaažiks

Paigaldamist/montaaži tohib läbi viia selleks volitusi omav spetsialist, arvestades kehtivaid nõudeid.

[fi] Belangrijke aanwijzingen betreffende de installatie/montage

De installatie/montage moet worden uitgevoerd door een voor de werkzaamheden geautoriseerde installateur. Hij moet rekening houden met de geldende voorschriften.

[fi] Tärkeitä asennus- ja kokoonpano-ohjeita

Näihin töihin hyväksytyn ammattiasentajan pitää suorittaa asennus- ja kokoonpanotyöt voimassa olevien määräysten mukaisesti.

[hu] Fontos tudnivalók az installáláshoz/szereléshez

Az installálást/szerelést egy, a munkákra felhatalmazott szakembernek kell végeznie, az érvényes előírások figyelembevételével.

[it] Avvertenze importanti per l'installazione/il montaggio

L'installazione/il montaggio deve aver luogo ad opera di una ditta specializzata ed autorizzata in osservanza delle disposizioni vigenti.

[he] מניפולציות/מонтаזים חשובות על התקנת המכשיר/התקנת המכשיר

התקנת המכשיר/התקנת המכשיר חייבת להיעשות על ידי מומחה מוסמך, המעריך את התנאים והמצב של המכשיר, ומבטיח את אמינותו.

[lt] Svarbios instaliavimo ir (arba) montavimo nuorodos

Instaliuoti ir montuoti, laikantis galiojančių taisyklių, leidžiamas kvalifikuotiems specialistams, kurie buvo įgijoti šiems darbams atlikti.

[lv] Svarīgi norādījumi par iekārtas uzstādīšanu / montāžu

Iekārtas uzstādīšanu/montāžu ir jāveic specializētam sertificētam speciālistam, ievērojot spēkā esošos noteikumus.

[nl] Belangrijke informatie over de installatie/montage

De installatie/montage moet worden uitgevoerd door een erkend installateur volgens de geldende voorschriften.

[no] Viktig informasjon om installasjon/montering

Installasjonen/monteringen skal gjennomføres av autoriserte installatører, og gjeldende forskrifter skal følges.

[pl] Ważne wskazówki dotyczące instalacji/montażu

Instalacja/montaż muszą być wykonane przez uprawnionego do tego rodzaju prac specjalistę przy zachowaniu obowiązujących przepisów.

[pt] Indicações importantes relativas à instalação/montagem

A instalação/montagem deve ser efetuada por um técnico especializado com qualificações para estes trabalhos, tendo em atenção os regulamentos em vigor.

[ro] Indicații importante privind instalarea/montajul

Instalarea/montajul trebuie realizate de către un specialist autorizat pentru lucrările respective, respectându-se prescripțiile valabile.

[ru] Важные указания по подключению/монтажу

Подключение/монтаж должны выполнять специалисты, имеющие допуск к выполнению таких работ, при соблюдении действующих норм и правил.

[sk] Dôležité pokyny týkajúce sa inštalácie/montáže

Inštaláciu/montáž musí realizovať odborník s oprávnením na výkon týchto prác, pričom musí dodržiavať platné predpisy.

[sl] Pomembni napotki za namestitev/montažo

Namestitev/montažo mora izvesti strokovnjak, pristojen za tovrstna dela, ob upoštevanju veljavnih predpisov.

[sr] Važna uputstva za ugradnju i montažu

Ugradnju i montažu moraju da obave samo stručna lica ovlašćena za izvođenje takvih radova koja će poštovati važeće propise.

[sv] Viktiga anvisningar för installation/montering

Installationen/monteringen måste utföras av en behörig och fackkunnig person enligt gällande föreskrifter.

[tr] Kurulum/Montaj ile ilgili önemli uyarılar

Kurulum/Montaj çalışmaları sadece yetkili bayiler tarafından aşağıda belirtilen talimatlar dikkate alınarak yapılmalıdır.

[uk] Важливі вказівки щодо установки/монтажу

Установку/монтаж мають здійснювати фахівці, що мають дозвіл на проведення цих робіт, із дотримання чинних приписів.

[zh] 安装方面的重要提示

必须由受到许可承担该项工作的专业人员遵照相关法规进行安装。

[ar] ملاحظات هامة للتركيب/التجميع

يجب أن يتم التركيب/التجميع من قبل متخصص مصرح له بالعمل، مع مراعاة اللوائح السارية.

[fa] تذکرات مهم درباره نصب/مونتاژ

نصب/مونتاژ باید توسط فردی حرفه ای که مجاز به انجام این کار است، و همچنین با توجه کامل به مقررات مربوطه انجام شود.

Ersatzteilliste
Spare parts list

Liste des pièces de rechange
Lista parti di ricambio

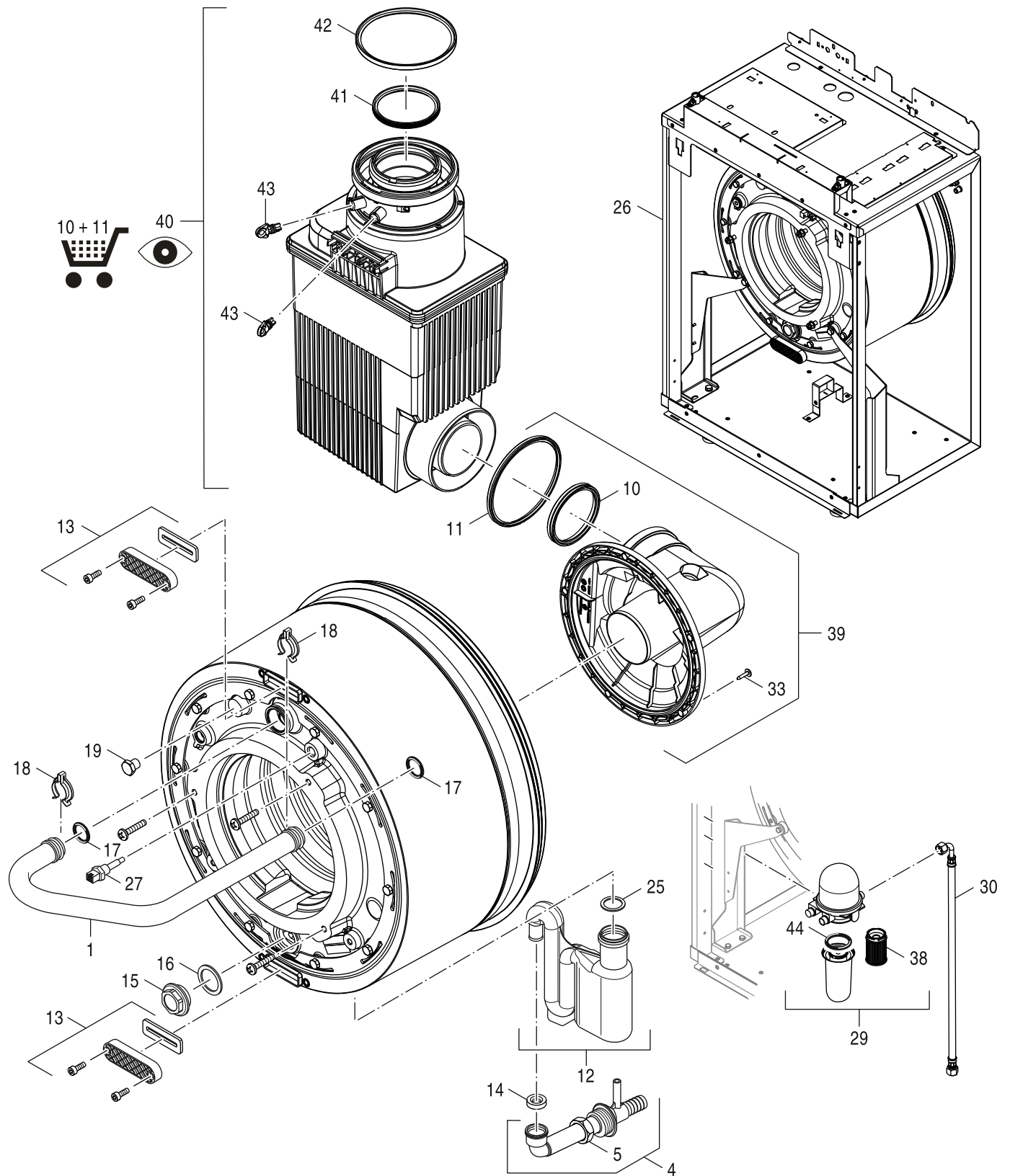

6721903733.aa.RO

1
Kesselblock
Boiler block
Bloc chaudière
Corpo caldaia

OC8000iF 19-25

Pos	Bezeichnung Description Dénomination Descrizioni	Bestell-Nr. Ordering no. Numéro de commande N° d'ordine																		Bemerkungen Remarks Remarques Osservazioni
			OC8000iF 19	OC8000iF 25																
1	Rohr 6Gld VK everp	8 718 583 241	■	■																
4	Kondensatablauf everp	8 718 583 245	■	■																
5	Gegenmutter PG29 5x everp	8 718 583 247	■	■																
10	Lippendichtung D80x10	8 718 223 472 0	■	■																
11	Lippendichtung D125x7,5	8 718 223 473 0	■	■																
12	Siphon	7 746 700 064	■	■																
13	Verschlussdeckel	8 715 503 528 0	■	■																
14	Lippendichtung DN18 (5x)	7 100 819	■	■																
15	Stopfen G 1 everp	8 718 584 633	■	■																
16	Dichtung D33x44x2 grafitiert everp	8 718 584 676	■	■																
17	O-Ring 28x3 70EPDM/281 everp	8 718 585 155	■	■																
18	Federclip d=38,2/28 everp 5Stk	8 718 571 056 0	■	■																
19	Stopfen G1/4 m O-Ring everp	8 718 586 403	■	■																
25	Lippendichtung (5x)	7 100 742	■	■																
26	Kesselblock CLA DNA 19/25kW BZ everp	8 738 807 192	■	■																
27	Kessel-/STB-FühlerG1/4 45lg everp	6 302 487 7	■	■																
29	Ölfilter B20 TOC-DUO A	8 718 577 407	■	■																
30	Schlauch ISO6806 6x1240/L20/90Gr Everp	7 736 605 902	■	■																
33	Flachkopfschraube St3,9x20 A2K (10x)ever	8 718 588 551	■	■																
38	Filtereinsatz Papier 5-20 Mikro mD everp	8 738 807 281	■	■																
39	Abgasstutzen Anschluss gewinkelt everp	8 738 807 118	■	■																
40	Abgasschalldämpfer everp	8 738 807 117	■	■																
41	Lippendichtung DN 80	8 738 901 447	■	■																
42	Lippendichtung DN125	7 736 700 058	■	■																
43	Stopfen	8 716 763 266 0	■	■																
44	O-Ring für Oventrop-Ölfilter	7 747 437 500	■	■																

OC8000iF 19-25

Kesselblock
Boiler block
Bloc chaudière
Corpo caldaia

1

Ersatzteilliste
Spare parts list

Liste des pièces de rechange
Lista parti di ricambio

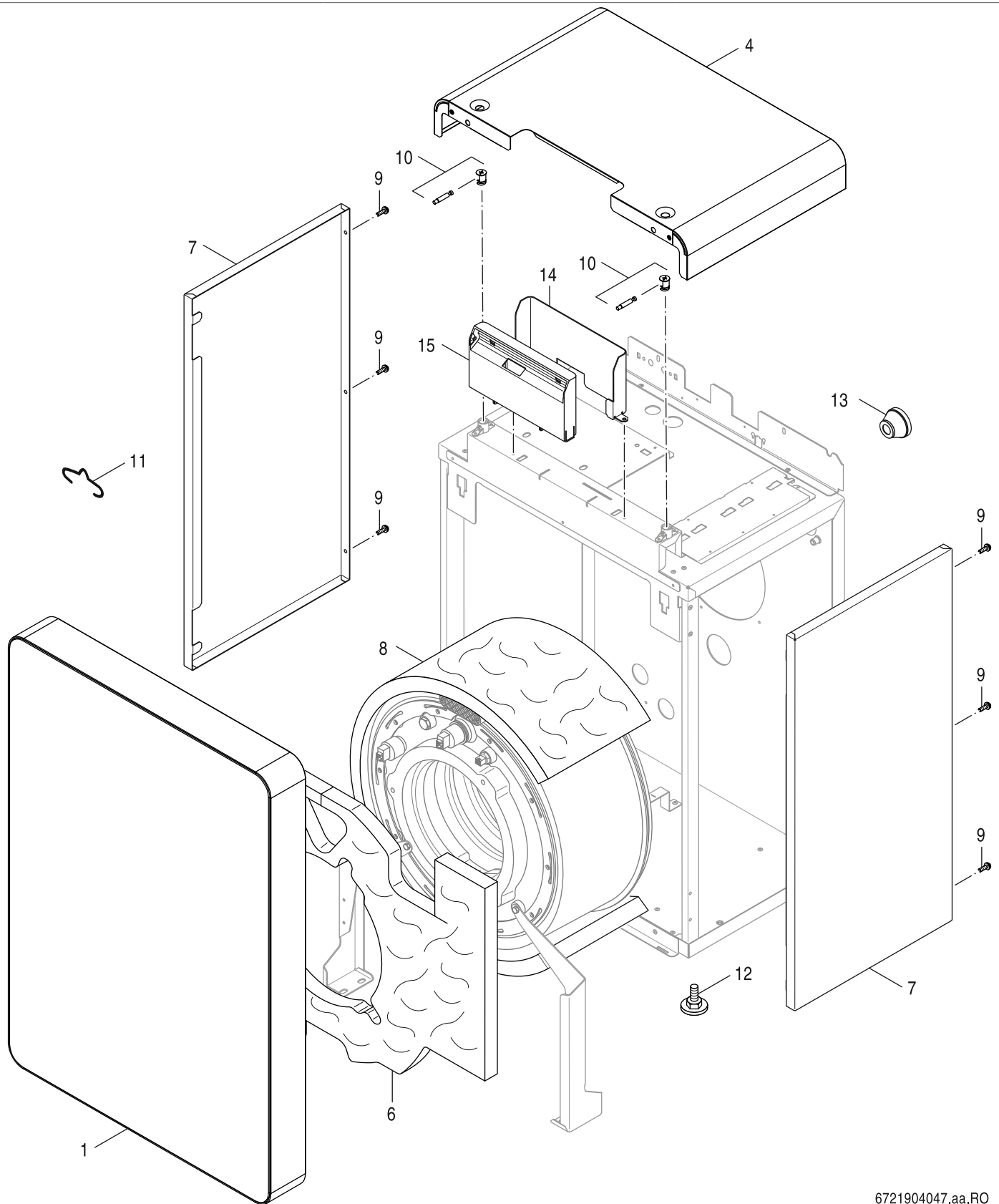

6721904047.aa.RO

2
Verkleidung
Casing
Habilage
Rivestimento

OC8000iF 19-25

Pos	Bezeichnung Description Dénomination Descrizioni	Bestell-Nr. Ordering no. Numéro de commande N° d'ordine	OC8000iF 19	OC8000iF 25																			Bemerkungen Remarks Remarques Osservazioni
1	Vorderwand GC8000iF V2 everp	8 738 806 755	■	■																			
4	Haube aussen GC8000iF 15-30kW V2 everp	8 738 806 756	■	■																			
6	Isolierung vorne everp	8 718 586 489	■	■																			
7	Seitenwand re/li 15-22-30kW everp	8 738 803 986	■	■																			
8	Wärmeschutz Block 6Gld everp	8 718 583 210	■	■																			
9	Flachkopfschraube ST3,9x9,5 A3T (10x)	7 747 026 999	■	■																			
10	Montageset Vorderwand XC8000F everp	8 738 807 062	■	■																			
11	Haltefeder (10x) everp	7 747 016 084	■	■																			
12	Gerätefuß M10x51 everp (4x)	6 302 865 7	■	■																			
13	Kabeldurchführung D46 / 4019 everp	8 718 583 389	■	■																			
14	Abdeckblech HMI V2 everp	8 738 806 753	■	■																			
15	Gehäuse Halter DNA RAL 7040 everp	8 738 806 754	■	■																			

OC8000iF 19-25	Verkleidung Casing Habilage Rivestimento	2
-----------------------	---	----------

Ersatzteilliste
Spare parts list

Liste des pièces de rechange
Lista parti di ricambio

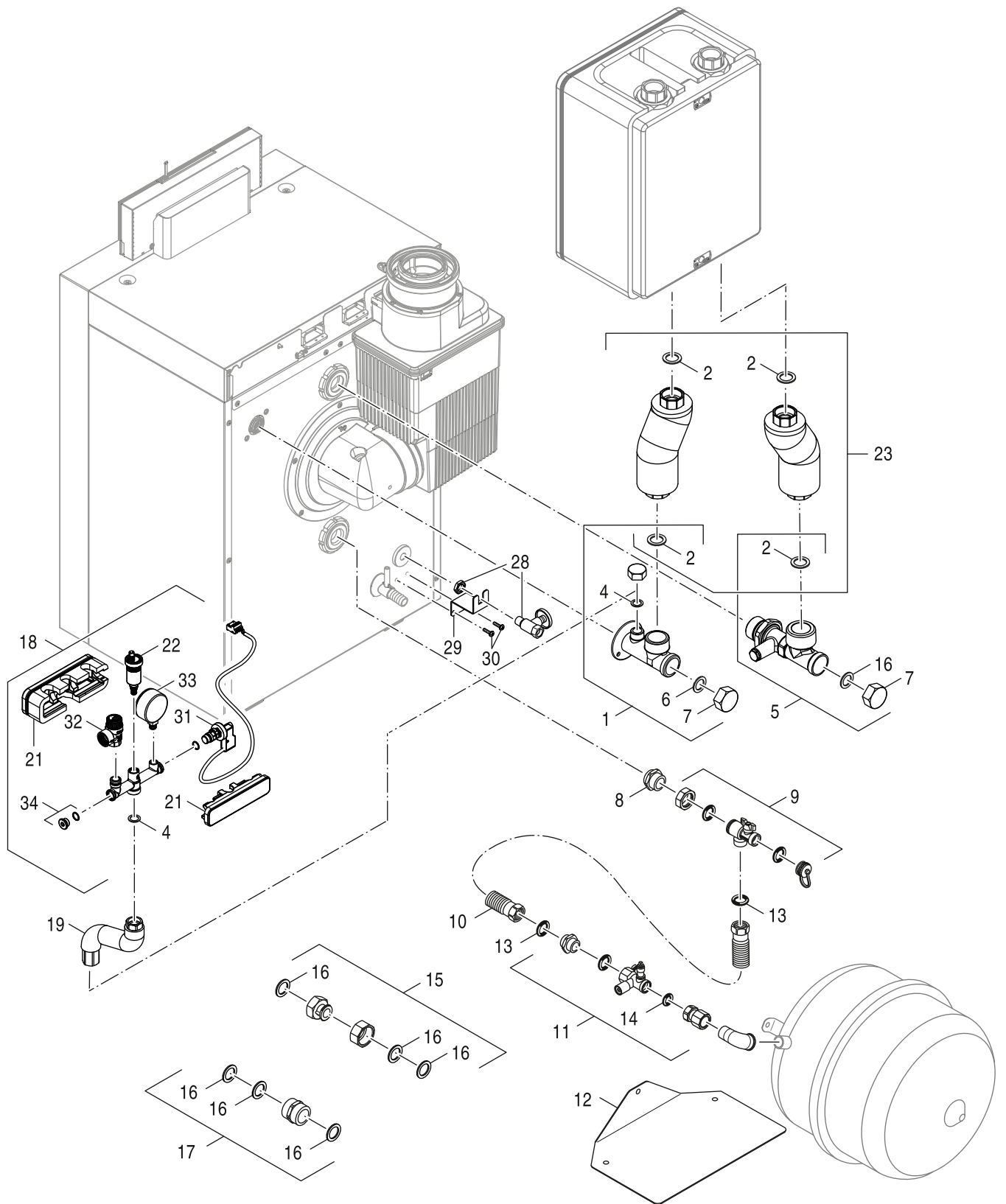

6721903744.ab.RO

3

Anschlußteile
Connection-parts
Raccordement
Collegamento

OC8000iF 19-25

Pos	Bezeichnung Description Dénomination Descrizioni	Bestell-Nr. Ordering no. Numéro de commande N° d'ordine																			Bemerkungen Remarks Remarques Osservazioni
			OC8000iF 19	OC8000iF 25																	
1	T-Stück G1 mit Muffe G3/4 VL V3 everp	8 738 803 862	■	■																	
2	Dichtung D27x38x2 DVGW zugel everp	8 718 584 801	■	■																	
4	Dichtung D17x24x2, DVGW-zugel	5 662 330	■	■																	
5	T-Stück G1 mit O-Ring Stopfen RL everp	8 738 807 703	■	■																	
6	O-Ring 29,82x2,62 EPDM (x5) everp	8 718 594 562	■	■																	
7	Verschlusskappe G1" everp	8 718 585 244	■	■																	
8	Doppelnippel G1x31 mit O-Ring everp	8 718 583 176	■	■																	
9	Füll und Entleerungshahn G1xG3/4 everp	8 718 585 245	■	■																	
10	Metallwellschlauch DN16 1000mm everp	8 738 804 516	■	■																	
11	Kappenventil flachdichtend 3/4x3/4 everp	6 302 542 7	■	■																	
12	Halblech Ausdehnungsgefäß	8 718 582 663	■	■																	Zubehör
13	O-Ring 22x2,5mm 70EPDM/281 (5x) everp	8 718 585 539	■	■																	
14	Dichtung D19x24,3x2mm AFM34 (5x) everp	8 718 571 898 0	■	■																	
15	Verschraubung G1-G1 everp	8 718 583 177	■	■																	
16	Dichtung D24x30,5x2 AFM34 (1x) everp	8 718 585 269	■	■																	
17	Doppelnippel G1x33 flachdichtend everp	6 303 627 0	■	■																	
18	Kessel-Sicherheits-Set BSS12 everp	8 738 807 109	■	■																	
19	Anschlussbogen BSS G3/4 D18x1 everp	8 738 807 112	■	■																	
21	Waermeisolierung EPP BSS11/12 everp	8 738 807 111	■	■																	
22	Entlüfter automatisch G3/8 everp	8 738 807 107	■	■																	
23	Anschluss-Set BCS35 verp	7 736 604 153	■	■																	Zubehör
28	Absperrventil G3/8" everp	6 302 264 4	■	■																	
29	Haltewinkel Öl-Absperrve 62x75x40 everp	8 718 587 163	■	■																	
30	Flachkopfschraube ST3,9x9,5 A3T (10x)	7 747 026 999	■	■																	
31	Druckschalter 0,7bar m Kabel everp	8 738 807 105	■	■																	
32	Sicherheitsventil 3bar everp	8 738 807 106	■	■																	
33	Druckmanometer D63 0-4bar everp	8 738 807 108	■	■																	
34	Verschlusskappe G3/8 everp	8 738 807 110	■	■																	

OC8000iF 19-25	Anschlußteile Connection-parts Raccordement Collegamento	3
-----------------------	---	----------

Ersatzteilliste
Spare parts list

Liste des pièces de rechange
Lista parti di ricambio

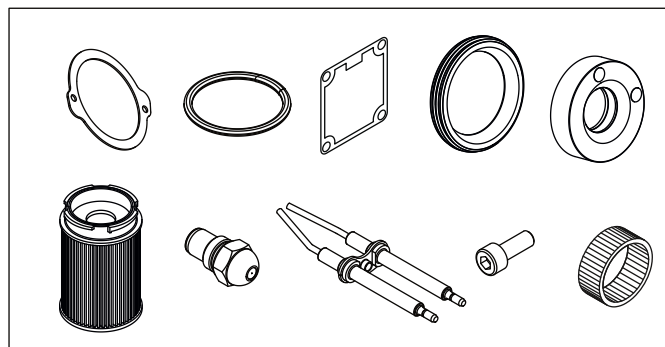
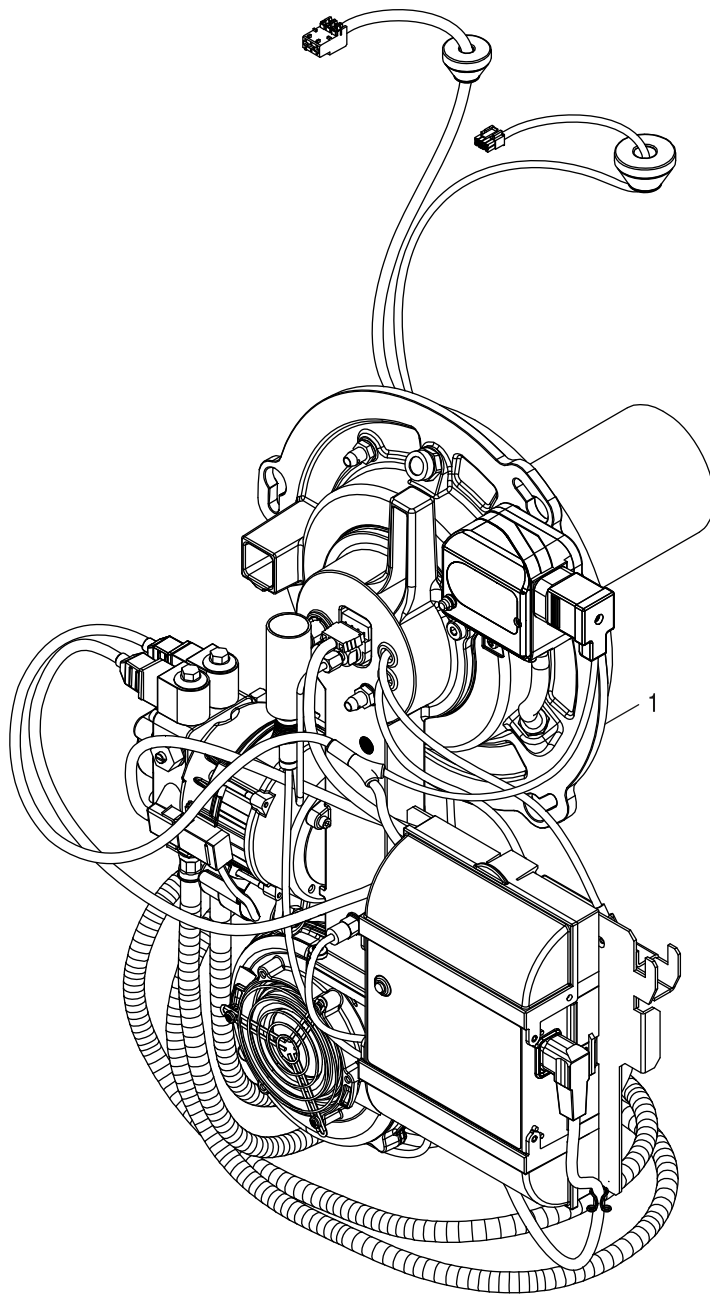

6721903584.aa.RO

4 Brennavarianten
burner versions
variantes de brûleur
varianti del bruciatore

OC8000iF 19-25

Pos	Bezeichnung Description Dénomination Descrizioni	Bestell-Nr. Ordering no. Numéro de commande N° d'ordine	OC8000iF 19	OC8000iF 25																		Bemerkungen Remarks Remarques Osservazioni
1	Ölbrenner BZ 1.1-25 kW everp	8 738 807 121	■																			
1	Ölbrenner BZ 1.1-19kW everp	8 738 807 249	■																			
5	Service-Set BZ 1.1 25kW everp	7 736 604 155	■																			
5	Service-Set BZ 1.1 19kW everp	7 736 604 258	■																			

OC8000iF 19-25	Brennervarianten burner versions variantes de brûleur varianti del bruciatore	4
-----------------------	--	----------

Ersatzteilliste
Spare parts list

Liste des pièces de rechange
Lista parti di ricambio

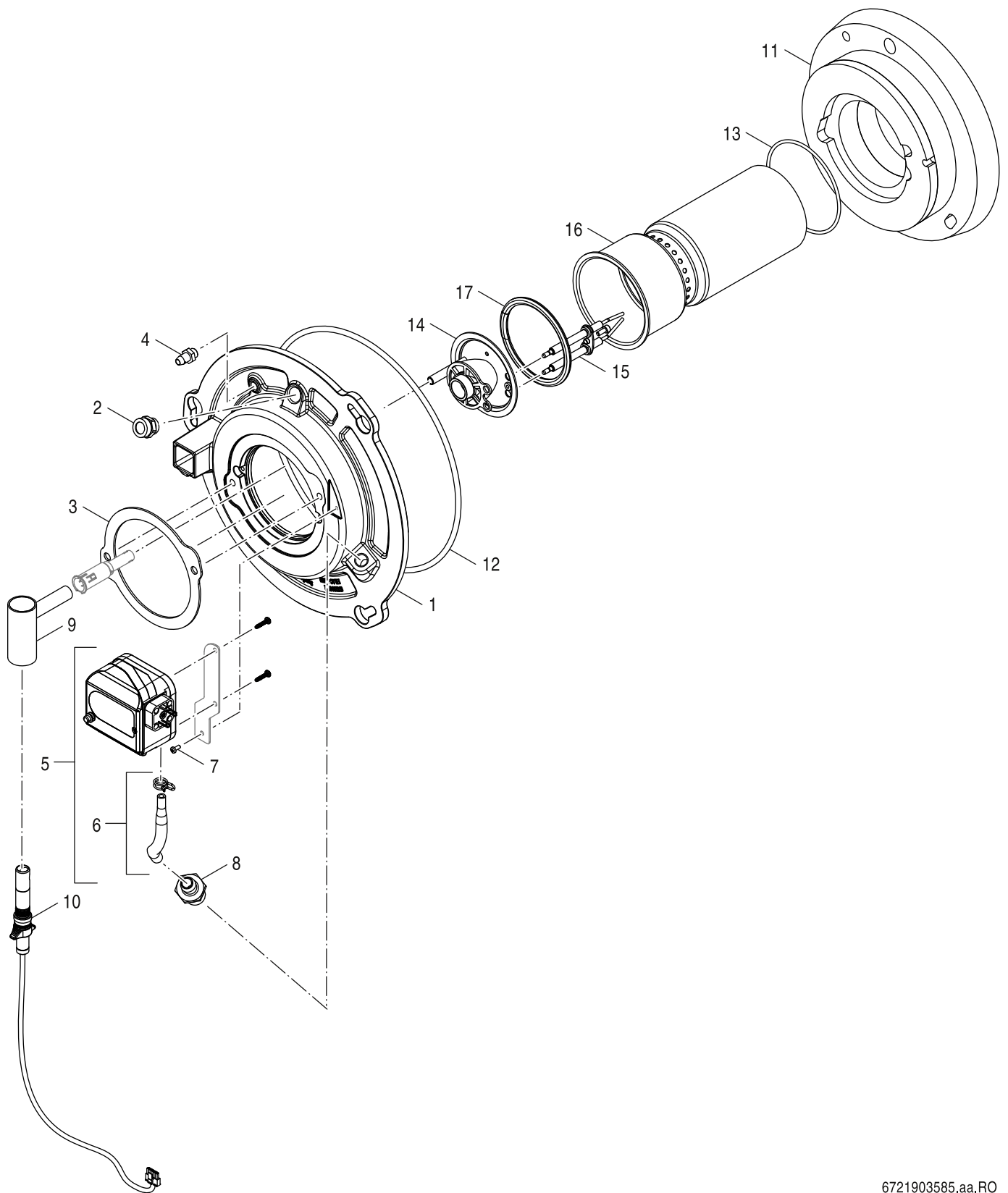

6721903585.aa.RO

4A Mischsystem/Brennerrohr
Mixing_unit/Burner tube
Chambre de melange/tuyère du brûleur
Modulo di miscelazione/boccaglio

OC8000iF 19-25

Pos	Bezeichnung Description Dénomination Descrizioni	Bestell-Nr. Ordering no. Numéro de commande N° d'ordine																	Bemerkungen Remarks Remarques Osservazioni
				OC8000iF 19															
				OC8000iF 25															
1	Brennerflansch BZ-1.1 everp	8 738 807 122	■	■															
2	Schauglas M16x1 kpl everp	8 718 589 884	■	■															
3	Dichtung D130xD106x2 V2 everp	7 747 004 201	■	■															
4	Druckmessdüse G1/8" everp	8 718 584 783	■	■															
5	Druckwächter DL 10KH-5 Z 290/70 kpl ev	8 738 807 390	■	■															
6	Schlauchset Druckwächter GB125-60 everp	7 736 603 349	■	■															
7	Linsensch DIN7985 M4x10 8.8A3K (4x) eve	8 718 583 000	■	■															
8	Einschraubstutzen D6 G1/4" SW17 everp	7 736 603 344	■	■															
9	Winkelhalter 90GR QRC everp	8 738 807 131	■	■															
10	Flammenfühler QRC SAFe BZ everp	8 732 924 882	■	■															
11	Isolierung Brennerflansch BZ 1.1 everp	8 738 807 123	■	■															
12	O-Ring 253,37 x 5,33 everp	8 718 583 004	■	■															
13	O-Ring 92x3 Viton everp	6 300 299 8	■	■															
14	Mischsystem BZ 1.1-25 everp	8 738 807 125	■																
14	Mischsystem BZ 1.1-19 everp	8 738 807 251	■																
15	Zündeflektrode BZ 1.1 everp	8 738 807 293	■	■															
16	Brennerrohr BZ 1.1-25 everp	8 738 807 124	■																
16	Brennerrohr BZ 1.1-19 everp	8 738 807 250	■																
17	Dichtung D81 V2 everp	8 718 585 504	■	■															

OC8000iF 19-25

Mischsystem/Brennerrohr
Mixing_unit/Burner tube
Chambre de melange/tuyère du brûleur
Modulo di miscelazione/boccaglio

4A

Ersatzteilliste
Spare parts list

Liste des pièces de rechange
Lista parti di ricambio

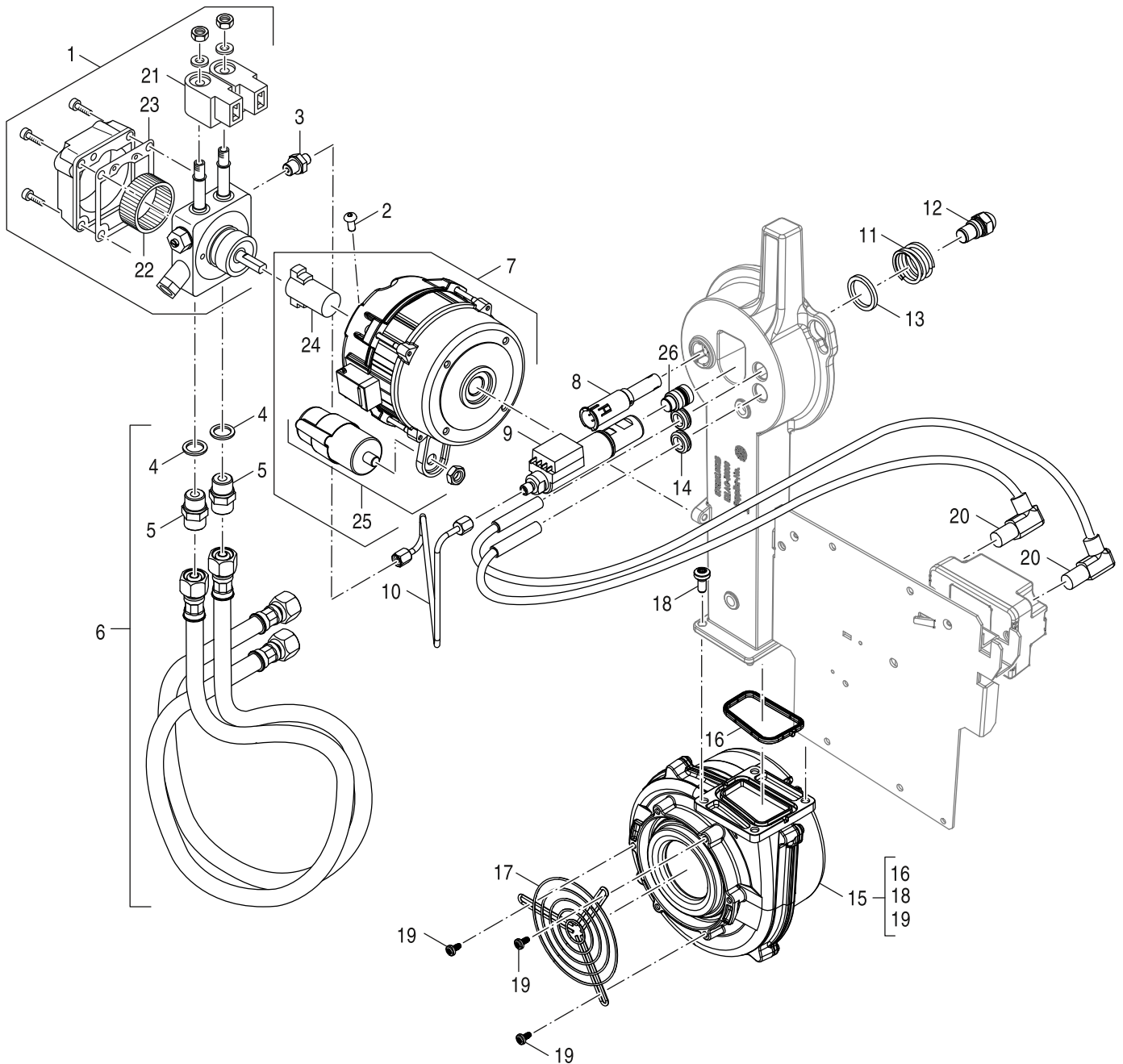

6721903586.aa.RO

4B
 Gebläse/Ölpumpe
 Fan/oil pump
 Ventilateur/pompe à fioul
 Ventilatore/Pompa gasolio

OC8000iF 19-25

Pos	Bezeichnung Description Dénomination Descrizioni	Bestell-Nr. Ordering no. Numéro de commande N° d'ordine																			Bemerkungen Remarks Remarques Osservazioni
			OC8000iF 19	OC8000iF 25																	
1	Ölpumpe Suntec ATE2V55D everp	8 718 577 409	■	■																	
2	Linsenschraube ISO7380 M5x12 (5x)everp	7 747 029 976	■	■																	
3	Einschraubversch GE 4LLR 1/8"Zyl everp	8 718 592 457	■	■																	
4	Dichtring 13x18x1,5 (5x) everp	8 718 584 808	■	■																	
5	Verschraubung G3/8" x G1/4" gerade everp	8 718 584 651	■	■																	
6	Schlauchset BE/RE	6 301 424 1	■	■																	
7	Motor 50W 230V 50Hz everp	8 718 590 894	■	■																	
8	Halterohr BZ 1.1 everp	8 738 807 126	■	■																	
9	Ölvorwärmer BZ-1.1 everp	8 738 807 127	■	■																	
10	Ölrohr BZ-1.1 everp	8 738 807 129	■	■																	
11	Feder 2,5x25,5x24 DIN 2099 everp	8 738 807 130	■	■																	
12	Öldüse 0,4gph 80Gr SR Danfoss everp	8 738 807 128	■	■																	
12	Öldüse 0,3gph 80Gr SR Danfoss everp	8 738 807 252	■	■																	
13	Dichtung D28xD22x3 everp	6 302 262 8	■	■																	
14	Kabeldurchführungen BZ 1.0 everp	6 303 977 1	■	■																	
15	Gebläse 118 AC230 50 120W PWM everp	8 738 806 978	■	■																	
16	Dichtung Gebläse	8 718 660 208 0	■	■																	
17	Schutzgitter NRG 118 everp	8 718 586 285	■	■																	
18	Schraube Ejot Altracs M6x14 (10x) everp	8 718 582 996	■	■																	
19	Schraube 40x8/7 TORX (10x) everp	7 746 900 442	■	■																	
20	Zündleitung Reakt. 1550 Ohm 275mm everp	8 732 919 563	■	■																	
21	Magnetspule Suntec220-240V/50-60Hz everp	7 747 021 595	■	■																	
22	Filter Ölpumpe A70 Rev.3 AS47 (2x)	8 718 572 496 0	■	■																	
23	Dichtung Ölpumpe ALE35/55 (2x) everp	8 718 572 498 0	■	■																	
24	Kupplung weiß (2x) 2-flächig	8 718 572 841 0	■	■																	
25	Kondensator 3MF 400V für Motor AEG everp	5 885 662	■	■																	
26	Abschlussventil LE6 everp	6 302 512 6	■	■																	

OC8000iF 19-25

Gebläse/Ölpumpe
 Fan/oil pump
 Ventilateur/pompe à fioul
 Ventilatore/Pompa gasolio

4B

Ersatzteilliste
Spare parts list

Liste des pièces de rechange
Lista parti di ricambio

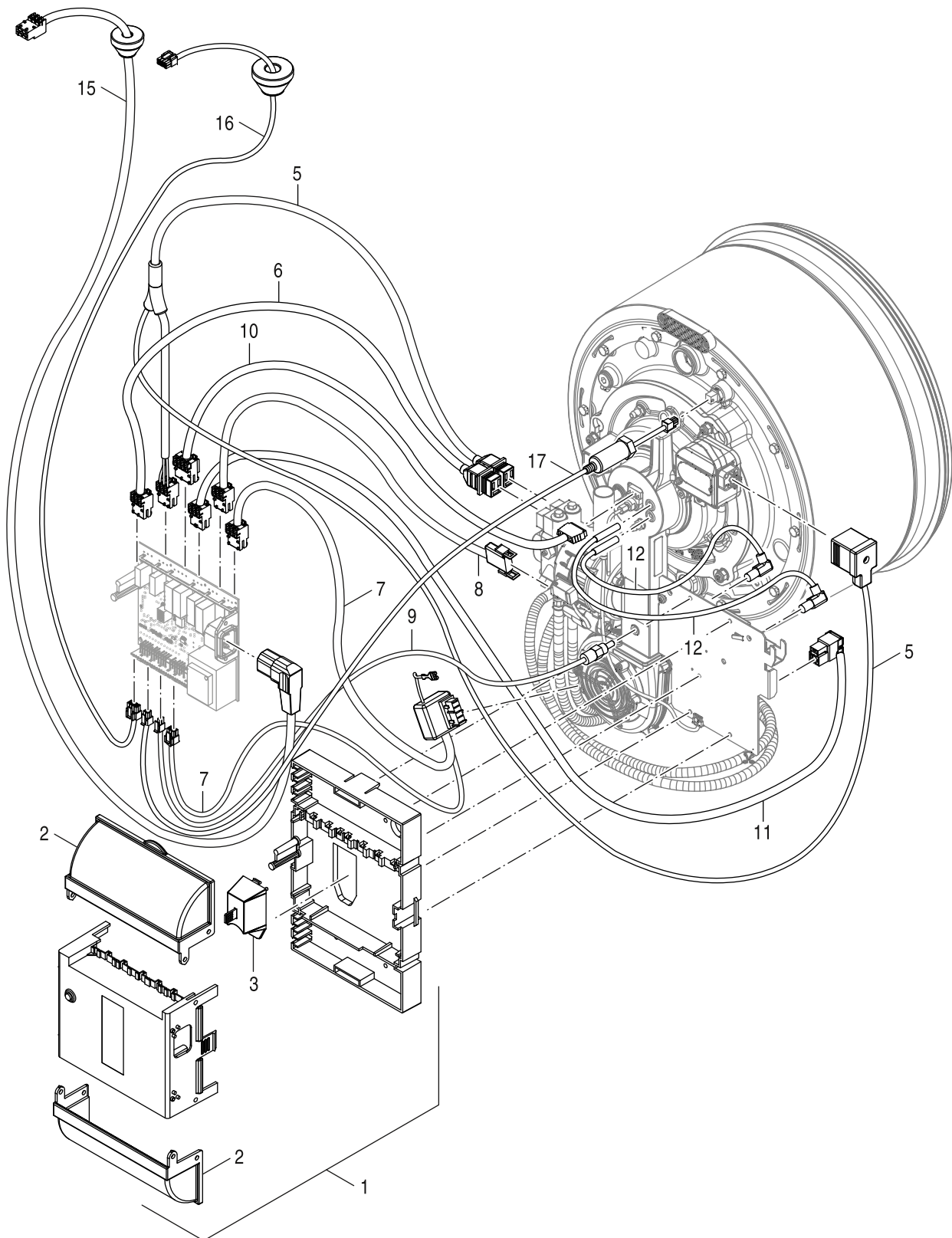

6721903587.aa.RO

4C
SAFe 30
SAFe 30
SAFe 30
SAFe 30

OC8000iF 19-25

Pos	Bezeichnung Description Dénomination Descrizioni	Bestell-Nr. Ordering no. Numéro de commande N° d'ordine																					Bemerkungen Remarks Remarques Osservazioni
1	SAFe30 V7 DNA everp	8 732 936 996	■	■																			
2	Gehäuse Klemmenabdeckung SAFe everp	6 302 392 5	■	■																			
3	Modul BIM30 5300-V24 KB195iT-19BZ everp	7 736 603 997	■																				Einbau nur durch ST
3	Modul BIM30 5301-V24 KB195iT-25BZ everp	7 736 603 998		■																			Einbau nur durch ST
5	Verbindungsleitung MV 1 Druck 570/350 ev	8 732 924 887	■	■																			
6	Verbindungsleitung MV 2 500 everp	8 732 924 888	■	■																			
7	Gebläseadapter 560/330 everp	8 732 924 889	■	■																			
8	Verbindungsleitung SAFe-Motor everp	6 302 260 0	■	■																			
9	Fühler Lufttemperatur everp	6 302 259 0	■	■																			
10	Verbindungsleitung Ölvorwärmer 375 everp	8 732 912 562	■	■																			
11	Zündleitung SAFe 230V everp	8 738 802 738	■	■																			
12	Zündleitung Reakt. 1550 Ohm 275mm everp	8 732 919 563	■	■																			
15	Verbindungsleitung SAFe - Netz 1350 everp	8 732 924 885	■	■																			
16	Datenleitung SAFe - RMx 1350 everp	8 732 924 886	■	■																			
17	Verbindungsitg Kesselfüh SAFeTülle everp	6 303 921 1	■	■																			

OC8000iF 19-25	SAFe 30 SAFe 30 SAFe 30 SAFe 30	4C
-----------------------	--	-----------

Ersatzteilliste
Spare parts list

Liste des pièces de rechange
Lista parti di ricambio

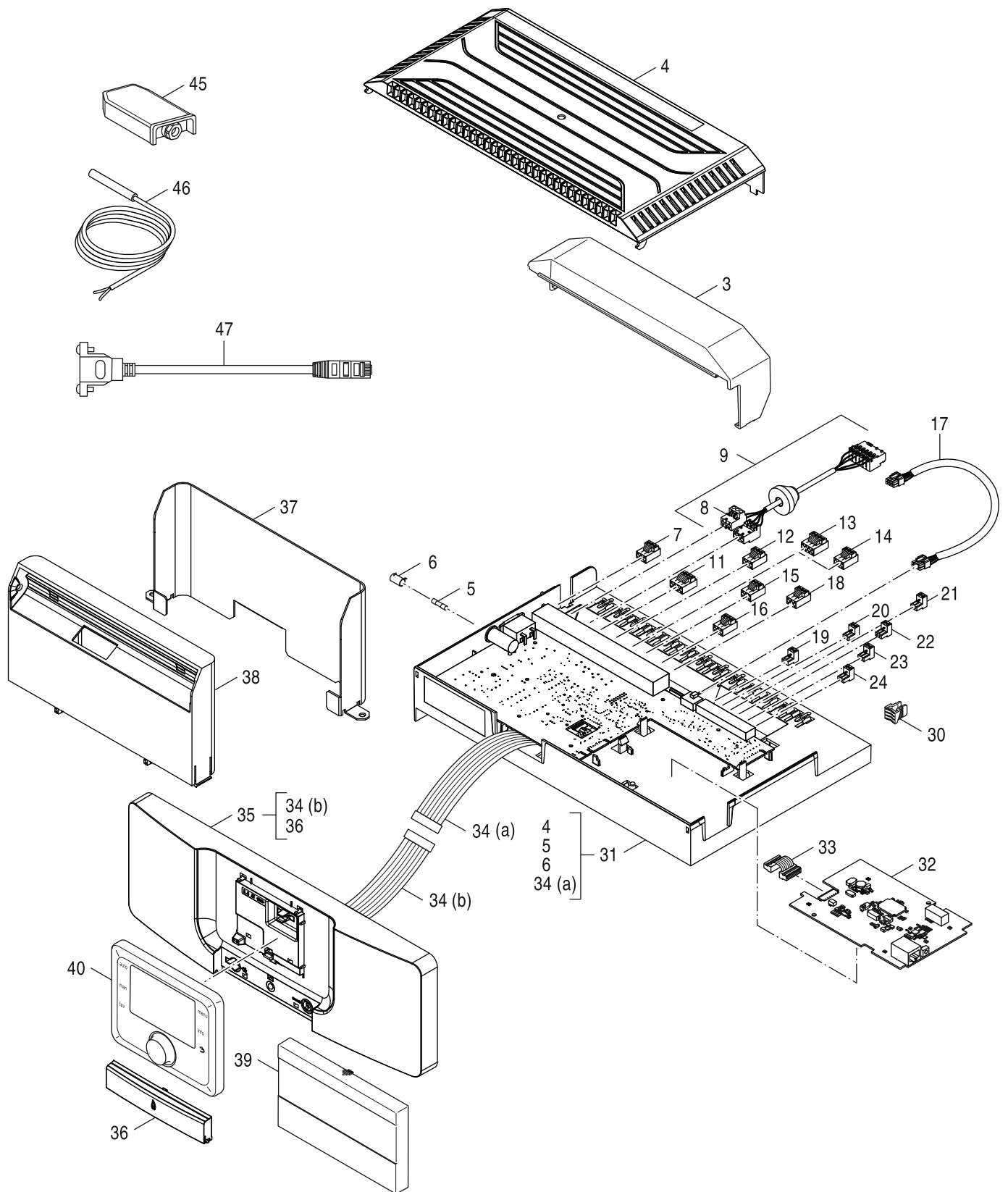

6721903518.aa.RO

9
IMX25i
IMX25i
IMX25i
IMX25i

OC8000iF 19-25

Pos	Bezeichnung Description Dénomination Descrizioni	Bestell-Nr. Ordering no. Numéro de commande N° d'ordine																						Bemerkungen Remarks Remarques Osservazioni
			OC8000iF 19	OC8000iF 25																				
3	Gehäuse Klemmabdeckung schwarz everp	7 736 603 857	■	■																				
4	Gehäuse Oberteil schwarz V1 everp	7 736 603 858	■	■																				
5	Sicherungseinsatz 5x20 6,3AT230V (10X)	8 718 578 518	■	■																				
6	Sicherungshalter-Kappe everp	8 718 221 358 0	■	■																				
7	Anschlussklemme 3-pol Netz weiß everp	7 747 023 981	■	■																				
8	Anschlussklemme 3-pol. SF50 rosa everp	8 718 586 071	■	■																				
9	Kabelbaum Power HV 1270 Ferrit everp	8 718 592 373	■	■																				
11	Anschlussklemme 4-pol orange 17B18 everp	8 718 590 270	■	■																				
12	Anschlussklemme 3-pol gelb everp	7 747 026 994	■	■																				
13	Anschlussklemme 4-pol viol. SH I Mischer	7 747 023 966	■	■																				
14	Anschlussklemme 3-pol.PS Pumpe grau everp	7 747 023 985	■	■																				
15	Anschlussklemme 3-pol. PZ Pumpe violett	7 747 023 986	■	■																				
16	Anschlussklemme 3-pol. PH grün everp	7 747 023 983	■	■																				
17	Datenleitung SAFe RMX 990mm everp	8 718 581 113	■	■																				
18	Anschlussklemme 3-pol. rot everp	8 718 586 111	■	■																				
19	Anschlussklemme 2-pol WA maigrün everp	7 747 023 154	■	■																				
20	Anschlussklemme 2-pol R5 blau everp	7 747 027 014	■	■																				
21	Anschlussklemme 2-pol grau FW	7 747 026 992	■	■																				
22	Anschlussklemme 2-pol toro EV Klemme	7 747 026 991	■	■																				
23	Anschlussklemme 2-pol. orang RC everp	7 747 023 151	■	■																				
24	Anschlussklemme 2-pol. weiss everp	7 747 023 129	■	■																				
30	Zugentlastung f. Regelgerät (10x) everp	8 718 583 348	■	■																				
31	Modul IMX25 Leiterplatte S13 everp	7 736 604 481	■	■																				
32	Leiterplatte IP*1 S06 everp	8 718 587 293	■	■																				
33	Kabelbaum MC100-IP*S01 everp	8 718 587 294	■	■																				
34	Leitung Set Bus BC110-IMC110 everp	8 732 909 190	■	■																				
35	Bedientableau BX25 S03 everp	8 732 900 424	■	■																				
36	Gehäuse Klappe MX25 everp	8 732 900 425	■	■																				
37	Abdeckblech HMI V2 everp	8 738 806 753	■	■																				
38	Gehäuse Halter DNA RAL 7040 everp	8 738 806 754	■	■																				
39	Blindabdeckung BC weiß everp	8 718 583 350	■	■																				
40	CW400 Bosch DE,AT,LU	7 738 113 412	■	■																			Zubehör	
40	CW400 Bosch CH,BE,IT	7 738 113 417	■	■																			Zubehör	
45	Außentemperaturfühler	8 747 207 101 0	■	■																				
46	Temperaturfühler NTC RD 6,0 12K 6000mm	7 735 502 304	■	■																				
47	CAT.5e/ RJ145 Kabel 500 everp	8 732 909 227	■	■																				
	LAN-Kabel 2000 everp	8 718 583 686	■	■																				

OC8000iF 19-25

IMX25i
IMX25i
IMX25i
IMX25i

9

Übersetzungsliste
List of translations

Liste des traductions
Traduzione delle descrizioni

Pos	Description	Denomination	Descrizione		
1	Element of construction	Groupe de construction	Gruppo di costruzione		
1	Pipe 6sec VK	Tube VK	Tubo VK		
4	Pipe drain	Évacuation des condensats	Scarico condensa		
5	Nut PG29	Contre-écrou	Controdado		
10	Lip seal D80x10	Joint à lèvres D80x10	Tenuta a labbro D80x10		
11	Lip seal D125x7,5	Joint à lèvres D125x7,5	Tenuta a labbro D125x7,5		
12	Syphon	Siphon	Sifone		
13	Cover - Service Access	Couvercle	Coperchio		
14	Sealing (5x)	Joint DN 18 (5x)	Guarn. anello con spig. di ten. DN18(5x)		
15	Plug G 1	BOUCHON G1	Tappo		
16	Gasket D33x44x2mm	Joint D33x44x2mm	Guarnizione		
17	O-ring D28x3mm 70EPDM/281 pckd	Joint torique D28x3 70EPDM/281	O-ring		
18	Spring d=38,2/28	Pince à ressort d=38,2/28	Molla		
19	Plug G 1/4	Bouchon G1/4	Tappo G1/4		
25	Lip seal (5x)	Joint (5x)	Guarnizione (5x)		
26	Boilerblock CLA DNA 19/25kW BZ everp	Corps de chauffe KB195i BZ 19/25kW everp	Elementi circuito interno caldaia KB195i		
27	Sensor boiler G1/4 45lang	Sonde chaudiere g1/4 GB402	Sonda Caldaia G1/4 45mm		
29	Filter oil B20 TOC-DUO A	Filtre à fioul B20 TOC-DUO A	Filtro del gasolio B20 TOC-DUO A		
30	Hose ISO6806 6x1240/L20/90Gr Everp	Tuyau souple,tube ISO6806 6x1240/L20/90G	Tubo flessibile ISO6806 6x1240/L20/90Gr		
33	Screw pan head ST3,9x20 A2K everp (10x)	Vis ST3,9x20 A2k (10x)	Vite St3,9x20 A2k (10x)		
38	Filter Paper 5-20 Mikro incl. Seal sp	Papier-filtre 5-20 Mikro avec joint	Carta da filtro 5-20 Mikro con sigillo		
39	Flue outlet elbow	Raccordement ventouse	Connessione aria/combusti in caldaia		
40	Flue Silencer	Piège à son everp	Silenziatore per gas combusti everp		
41	Lip seal DN 80	Joint DN 80	Guarnizione DN 80		
42	Shaped seal DN125	Joint à lèvres DN125	Guarn. anello + spig. tenuta DN125		
43	Grommet	Bouchon a/joint	Coperchietto		
44	OV O-Ring f.Oilfilter f.Bio-Oil, green	Joint torique pour filtre huile Oventrop	O-ring per filtro olio Oventrop		
2	Element of construction	Groupe de construction	Gruppo di costruzione		
1	FRC GC8000iF sp	Panneau avant GC8000if V2	Parete anteriore GC8000iF V2		
4	Hood outside GC8000iF 15-30kW sp	Capot extérieur GC8000iF 15-30kW V2	Coperchio esterno GC8000iF 15-30kW V2		
6	Insulation front	Isolation avant	Coibentazione anteriore		
7	Sheet ri/le 15-22-30kW	Face latérale 15-22-30kW	Parete laterale 15-22-30kW		

Übersetzungsliste
List of translations

Liste des traductions
Traduzione delle descrizioni

Pos	Description	Denomination	Descrizione		
8	Insulation Block 6sec	Isolation bloc	Coibentazione blocco		
9	Pan-head screw ST3,9x9,5 A3T (10x)	Vis à tête plate ST3,9 (10x)	Vite a testa piana ST3,9x9,5 (10x)		
10	Installation kit panel front XC8000F	Kit de montage panneau avant XC8000F	Set di montaggio parete anteriore		
11	Insulation Clamp (10x)	Ressorts de retenue d 0.8 (10x)	Molla di tenuta (10x)		
12	Foot M10x51 (4x)	Pieds réglables M10x51 (4x)	Piedini regolabili M10x51 (4x)		
13	Hose D46 / 4019	Entrée de câble	Ingresso cavi		
14	Sheet cover for HMI V2 sp	Tôle de recouvrement HMI V2	Pannello di copertura HMI V2		
15	Housing Holder DNA RAL 7040 sp	Boîtier support DNA RAL 7040	Involucro supporto DNA RAL 7040		
3	Element of construction	Groupe de construction	Gruppo di costruzione		
1	T-Piece G1 with sleeve G3/4 VL V3 sp	Raccord en T G1 Manchon G3/4 V3	Raccordo a T G1 Manicotto G3/4 V3		
2	Seal D27x38x2 DVGW packed	Joint D27x38x2mm C4400 Klinger SIL	Guarnizione 27x38x2mm C4400 Klinger SIL		
4	Gasket D17x24x2mm C4400 Klinger SIL,	Joint D17x24x2mm C4400 Klinger SIL, vert	Guarnizione		
5	T-piece G1 with O-ring plug RL s.p.	Raccord en T G1 RL	Raccordo a T G1 RL		
6	O-ring 29,82x2,62 EPDM (x5) packed	Joint torique 37x3 EPDM (x5)	O-ring 29,82x2,62 EPDM (x5)		
7	Cover G1" packed	Capuchon G1"	Tappo G1"		
8	Nipple double G1x31 with o-ring	Double mamelon	Doppio capezzolo		
9	Valve Fill and drain G1xG3/4 packed	robinet remplissage et vidange G1xG3/4	rubinetto di carico e scarico		
10	Tube flute steel DN16 1000mm packed	Flexible métallique DN16 1000mm	Tubo metallico ondulato DN16 1000mm		
11	Cap valve flat sealing 3/4x3/4	Soupape	Tappo della valvola		
12	Accessory base plate expansion tank	Plaque de jonction vase d'expansion	Lamierino vaso di espansione		
13	O-ring 22x2,5 70EPDM/281 (5x)	Joint torique 22x2,5 70EPDM/281 (5x)	O-ring 22x2,5 70EPDM/281 (5x)		
14	Seal D19x24,3x2mm AFM34 (5x)	Joint D19x24,3x2mm AFM34 (5x)	Guarnizione D19x24,3x2mm AFM34 (5x)		
15	Fitting Connection G1-G1	Raccord sonde sanitaire	Serraggio a vite		
16	Seal D24x30,5x2 AFM34 (1x) packed	Joint D24x30,5x2 AFM34 (1x)	Guarnizione D24x30,5x2 AFM34 (1x)		
17	Double nipple G1x33 flat sealing	Nipple double G1x33mm (étanche)	Nipples doppio G1x33mm (a guarnizione pi)		
18	Boiler Safety Set BSS12 packed	Ensemble de la sécurité de BSS12	Set sicurezza caldaia BSS12		
19	Pipe connection BSS G3/4 D18x1 packed	Tube de liaison BSS G3/4 D18x1	Tubo di collegamento BSS G3/4 D18x1		
21	Insulation EPP BSS11/12 packed	Isolation EPP BSS11/12	Coibentazione EPP BSS11/12		
22	Air_vent automatic G3/8 packed	Purger automatiquement G3/8	Bleeder automaticamente G3/8		
23	Accessory heating circuit BCS35	Anschluss-Set BCS35 verp			
28	Shut-off valve G3/8"	Vanne d'arrêt G3/8"	Valvola di intercettazione G3/8"		
29	Sheet 62x75x40	tôle de fixation 62x75x40	Angolare di sostegno 62x75x40		

Übersetzungsliste
List of translations

Liste des traductions
Traduzione delle descrizioni

Pos	Description	Denomination	Descrizione		
30	Pan-head screw ST3,9x9,5 A3T (10x)	Vis à tête plate ST3,9 (10x)	Vite a testa piana ST3,9x9,5 (10x)		
31	Switch pressure 0.7bar w cable packed	Contact à pression 0,7bar	Pressostato 0,7bar		
32	Safety Valve 3bar packed	Soupape de sécurité 3bar	Valvola di sicurezza 3bar		
33	Gauge pressure D63 0-4bar packed	Manomètre D63 0-4bar	Manometro D63 0-4bar		
34	Cap closure G3/8 packed	Bouchon G3/8	Tappo G3/8		
4	Element of construction	Groupe de construction	Gruppo di costruzione		
1	Burner oel BZ 1.1-25kW sp	brûleur fioul BZ 1.1-25 kW	bruciatore a gasolio BZ 1.1-25 kW		
1	Burner oel BZ 1.1-19kW sp	brûleur fioul BZ 1.1-19kW	bruciatore a gasolio BZ 1.1-19kW		
5	Service-Set BZ 1.1 25kW sp	Set de service BZ 1.1 25kW	Imballato BZ 1.1 25kW		
5	Service-Set BZ 1.1 19kW sp	Set de service BZ 1.1 19kW	Imballato BZ 1.1 19kW		
4A	Element of construction	Groupe de construction	Gruppo di costruzione		
1	Flange burner BZ-1.1 sp	Brûleur Trappe de visite BZ-1.1	Bruciator Flangia BZ-1.1		
2	Glass_sight M16x1 kpl	verre du viseur M16x1	vetrino M16x1		
3	Gasket D130xD106x2 V2	Joint D130x106x2 V2	Guarnizione D130x106x2 V2		
4	Pressure tapping G1/8"	Prise de pression G1/8"	Presa pressione G1/8"		
5	Switch DL 10KH-5 Z 290/70 cpl sp	contrôle pression DL 10KH-5 Z 290/70	Pressostato DL 10KH-5 Z 290/70		
6	hose pressure switch GB125-60	JEU DE FLEXIBLE BLEU/ ROUGE	Tube flessibile (set)		
7	Screw DIN7985 M4x10 8.8A3K (4x)	Vis à tête bombée DIN 7985 M4x10 8.8A3K	Vite DIN7985 M4x10 8.8A3K (4x)		
8	Screw in socket D6 G1/8" SW17	Buse D6 G1/8"	Giunto D6 G1/8"		
9	Angle holder 90Gr QRC sp	Support 90GR QRC	Supporto 90GR QRC		
10	Sensor QRC SAFe BZ everp	sonde de détection de flamme QRC SAFe BZ	sensore di fiamma QRC SAFe BZ		
11	Insulation burner flange BZ 1.1 sp	Isolation bride de bruleur BZ 1.1	Coibentazione Flangia BZ 1.1		
12	O-ring 253,37 x 5,33	Joint torique 253,37 x 5,33	Anello tenuta 253,37 x 5,33		
13	O-ring 92x3	Joint etancheite d 93x3 mm4	O-Ring 92x3 Viton everp		
14	Mixing_unit BZ 1.1-25 sp	Chambre de melange BZ 1.1-25	Modulo di miscelazione BZ 1.1-25		
14	Mixing_unit BZ 1.1-19 sp	Chambre de melange BZ 1.1-19	Modulo di miscelazione BZ 1.1-19		
15	Ignition elec BZ 1.1 sp	électrode d'allumage BZ 1.1	elettrodo di accensione BZ 1.1		
16	Burner tube BZ 1.1-25 sp	tuyère du brûleur BZ 1.1-25	boccaglio BZ 1.1-25		
16	Burner tube BZ 1.1-19 sp	tuyère du brûleur BZ 1.1-19	boccaglio BZ 1.1-19		
17	Seal D81 V2 everp	JOINT DE TUYERE D81 V2	Dichtung D81 V2		
4B	Element of construction	Groupe de construction	Gruppo di costruzione		
1	Pump oil Suntec ATE2V55D	Pompe à fioul Suntec ATE2V55D	Pompa gasolio Suntec ATE2V55D		

Übersetzungsliste
List of translations

Liste des traductions
Traduzione delle descrizioni

Pos	Description	Denomination	Descrizione		
2	Screw Pan-Head ISO7380 M5x12 (5x)	Vis à tête bombée ISO7380 M5x12 (5x)	Vite a testa bombata ISO7380 M5x12 (5x)		
3	Screw connection XGE 4LLR 1/8" cyl.	RACC DROIT VIS XGE 4 LLR 1/8"	Raccordo XGE 4LLR 1/8"		
4	Washer 13x18x1,5 (5x)	Joint 13x18x1,5 (5x)	Guarnizione 13x18x1,5 (5x)		
5	Screw connection 3/8x1/4" straight	RACCORD 3/8"X1/4",DROIT	Raccordo 3/8x1/4"		
6	Hose set BE/RE	Conduit flexible set BE	Tubo flessibile (set) BE / RE		
7	Motor 50W 230V 50Hz SP	Moteur 50W 230V 50Hz	Motore 50W 230V 50Hz		
8	Support pipe BZ 1.1-burner sp	TUBE MAINTIEN BZ 1.1	Holds pipe BZ 1.1		
9	Oil pre heater BZ-1.1 sp	Préchauffeur d'huile BZ-1.1	preriscaldatore del gasolio BZ-1.1		
10	Oil pipe BZ-1.1 sp	Conduite fioul BZ-1.1	Tubazione del gasolio BZ-1.1		
11	Spring 2,5x25,5x24 DIN 2099 sp	ressort 2,5x25,5x24 DIN 2099	Molla 2,5x25,5x24 DIN 2099		
12	Oil Nozzle 0.40gph 80deg SR Danfoss sp	gicleur fioul 0,4gph 80Gr SR Danfoss	ugello per gasolio 0,4gph 80Gr SR Danfos		
12	Oil Nozzle 0.30gph 80deg SR Danfoss sp	gicleur fioul 0,3gph 80Gr SR Danfoss	ugello per gasolio 0,3gph 80Gr SR Danfos		
13	Seal D28x22x3	Joint D28x22x3	Guarnizione D28x22x3		
14	Grommet BZ 1.0	Passe fill BZ 1.0	Passacavo BZ 1.0		
15	Fan P EBM D118 AC230 50 120W PWM spare	ventilateur P EBM D118 AC230 50 120W PWM	ventilatore P EBM D118 AC230 50 120W PWM		
16	Seal centrifugal blower	Joint ventilateur	Ventola della guarnizione		
17	Grille for fan NRG 118	grille de protection NRG 118	griglia di protezione NRG 118		
18	Screw Ejot Altracs M6x14 (10x)	vis Ejot Altracs M6x14 (10x)	Vite Ejot Altracs M6x14 (10x)		
19	Screw 40x8/7 TORX (10x)	Vis 40x8/7 TORX (10x)	Vite 40x8/7 TORX (10x)		
20	Ignition Reaktanz 1550 Ohm 275mm everp	CABLE ALLUM Reakt. 1550 Ohm 275mm	Cavetto accensione Reakt. 1550 Ohm 275mm		
21	solenoid coil Suntec 220-240V/50-60Hz	Bobine electrovanne pompe suntec	Bobina magnetica Suntec 220-240V/50-60Hz		
22	filter oil pump A70 Rev.3 AS 47 (2x)	Filtre Pompe à fioul A70 Rev.3 AS47 (2x)	Filtro Pompa gasolio A70 Rev.3 AS47 (2x)		
23	gasket oil pump ALE 35/55 (2x)	JOINT COUVERCLE POMPE SUNTEC AS 47 (2x)	Guarnizione Pompa gasolio ALE 35/55 (2x)		
24	Clutch white (2x)	Accoupl mot.- pompe fioul 2 meplats(2x)	Accoppiamento bianco (2x)		
25	Capacitor 3µF	Condensateur 3âf moteur hg 90w	Condensatore 3MF		
26	Cut-off valve LE6 sp	Clapet retenu le6	Valvola a membrana LE6		
4C	Element of construction	Groupe de construction	Gruppo di costruzione		
1	Control_box SAFe30 V7 DNA SP	SAFe30 V7 DNA	SAFe30 V7 DNA		
2	Housing Terminal cover SAFe	Couvercle safe GB402	Coperchio SAFe		
3	Module BIM30 5300-V24 KB195iT-19BZ sp	Module BIM30 5300-V24 KB195iT-19BZ	Modulo BIM30 5300-V24 KB195iT-19BZ		
3	Module BIM30 5301-V24 KB195iT-25BZ sp	Module BIM30 5301-V24 KB195iT-25BZ	Modulo BIM30 5301-V24 KB195iT-25BZ		
5	Cable MV 1 Pressure 570/350 everp	câble de connexion MV 1 Druck 570/350	tubazione di collegamento MV 1 Druck 570		

Übersetzungsliste
List of translations

Liste des traductions
Traduzione delle descrizioni

Pos	Description	Denomination	Descrizione		
6	Cable MV2 500 everp	câble de connexion MV 2 500	tubazione di collegamento MV 2 500		
7	Cable Fan Adapter 560/330 everp	ventilateur adaptateur 560/330	ventilatore adattatore 560/330		
8	Connection line SAFe motor	Conduite de raccordement SAFe-Motor	Cablaggio di collegamento SAFe-Motor		
9	Sensor Air temperature	Sonde de température	Sensore sicurezza di temperatura		
10	Cable Oil heater 375 everp	Cable rechauffeur 375	Tubazione di collegamento 375		
11	Ignition cable SAFe 230 V	Cable allumage - safe	Cavetto accensione SAFe 230V		
12	Ignition Reaktanz 1550 Ohm 275mm everp	CABLE ALLUM Reakt. 1550 Ohm 275mm	Cavetto accensione Reakt. 1550 Ohm 275mm		
15	Cable SAFe - Power 1350 everp	cordons branchement réseau 1350	cavo di rete 1350		
16	Cable strand SAFe - RMx 1350 everp	câble de connexion SAFe - RMx 1350	tubazione di collegamento SAFe - RMx 135		
17	Con cable sensor SAFe socket	Conduite de raccordement SAFe	Tubazione di collegamento SAFe		
9	Element of construction	Groupe de construction	Gruppo di costruzione		
3	Housing cover plug black	Revêtement noir	Pannello protettivo nero		
4	Housing top part black V1	Carter haut noir V1	Involucro sopra nero V1		
5	Fuse application 5x20 6,3AT 230V (10x)	Fusible arrière 5x20 6,3AT 230V (10x)	Fusibile posteriore 5x20 6,3AT 230V(10x)		
6	Fuseholder cap	Support de fusible	Porta fusibile		
7	Connector 3-pole white	Borne de connexion 3- pôles blanc	Morsetto di collegamento 3-bipol. bianco		
8	Connector 3-pol. SF50 pink	Borne de raccordement 3-poles SF50 rose	Morsetto di collegamento 3-pol.SF50 rosa		
9	Wire Power HV 1270 Ferrit everp	faisceau de câbles Power HV 1270 Ferrit	Cablaggio Power HV 1270 Ferrit		
11	Connector 4-pol 17B18 orange	Borne de raccordeme 4 poles 17B18 orange	Morsetto di collegamento 4-pol. 17B18		
12	Connecting terminal pluggable 3-pol	Borne de connexion 3- pôles jaune	Morsetto di collegamento 3-bipol. giallo		
13	Connector 4-pole SH I violet	Borne de connexion 4- pôles SH I violet	Morsetto di collegame.4-bipol.SH I viol.		
14	Connector 3-pole PS grey	Borne de connexion 3- pôles ps gris	Morsetto di collegamento 3-pol.PS grigio		
15	Connector 3-pole PZ violett	Connecteur 3 poles violet	Morsetto di collegamento - pol.PZ violett		
16	Connector 3-pole PH green	Borne de connexion 3- pôles PH vert	Morsetto di collegamento 3-pol. PH verde		
17	Wire SAFe - RMx 990mm	CABLES DONNEES SAFe RMx 990mm	Cavo dati SAFe RMx 990mm		
18	Connector 3-pol. AS red sparepart	Borne de raccordement 3-poles AS rouge	Morsetto di collegamento3-bipol.AS rosso		
19	Connecting terminal 2-polig WA maygreen	Fiche verte 2 poles wa	Morsetto di collegamento2-bipol WA verde		
20	Connector 2- pin blue	Borne de connexion 2- pol r5 bl everp	Morsetto di collegamento 2-bipolare blu		
21	Connector 2-pole grey FW	Borne de connexion 2- pôles gris FW	Morsetto di collegame.2-bipol. grigio FW		
22	Connect. term. 2-polig red	Fiche rouge 2 poles	Morsetto di collegamento2-bipolare rosso		
23	Connector 2- pin orange RC	Borne de connexion 2- pôles orange RC	Morsetto di collegamento2-bip.arancione		
24	Connector 2-pole white	Borne de connexion 2-poles blanc	Morsetto di collegamento2-pol bianco		

Übersetzungsliste
List of translations

Liste des traductions
Traduzione delle descrizioni

Pos	Description	Denomination	Descrizione		
30	Housing strain relief control (10x)	Décharge de traction (10x)	Fermo antitrazione (10x)		
31	Module IMX25 PCB S13	Module IMX25 circuit imprimé S13	Modulo IMX25 Scheda elettronica S13		
32	PCB IP*1 S06	circuit imprimé IP*1 S06	circuito stampato IP*1 S06		
33	Cable harness MC100-IP*S01	faisceau de câbles MC100-IP*1 S01	Cablaggio MC100-IP*1 S01		
34	Strand set bus BC110-IMC110	Jeu de câbles Bus BC110-IMC110	Set di cavi Bus BC110-IMC110		
35	Control element BX25 S03	Élément de commande BX25 S03	Elemento di servizio BX25 S03		
36	Casing flap MX25	Boîtier couvercle MX25	Involucro copertura di protezione MX25		
37	Sheet cover for HMI V2 sp	Tôle de recouvrement HMI V2	Pannello di copertura HMI V2		
38	Housing Holder DNA RAL 7040 sp	Boîtier support DNA RAL 7040	Involucro supporto DNA RAL 7040		
39	Housing blind cover BC white	Couvercle BC blanc	Copertura BC		
40	CW400 Bosch DE,AT,LU	CW400 Bosch DE,AT,LU	CW400 Bosch DE,AT,LU		
40	CW400 Bosch CH,BE,IT	CW400 Bosch CH,BE,IT	CW400 Bosch CH,BE,IT		
45	Outside temperature sensor	Sonde de température extérieure	Sonda esterna		
46	Temperature sensor NTC RD 6,0 12K 6000mm	Kit capteurs NTC RD 6,0 12K 6000 emballé	Sonda di temperatura NTC RD 6,0 12K 6000		
47	Wire CAT.5e Patch Cable 500	Câble 500	Cavo conduttore 500		
	LAN-Cable RJ45 Cat.5 2000	LAN-câble 2000	LAN-Cavo 2000		

Gerätetypen
Types of appliances

Types de chaudières
Tipo apparecchi

Gerät Appliance Chaudière Apparecchio	Bestell-Nr. Ordering no. Numéro de commande N° d'ordine	Land Country Pays Paese	Bemerkungen Remarks Remarques Osservazioni
OC8000iF 19	8 732 946 724	Deutschland,Dänemark,Luxemburg,Schweiz	
OC8000iF 25	8 732 946 725	Deutschland,Dänemark,Luxemburg,Schweiz	



BOSCH

Bosch Thermotechnik GmbH
Junkersstr. 20-24
D-73249 Wernau / Germany