

Technische Daten

Schrankspeicher

Type SSP 120-200-250-300



200-250-300 Liter

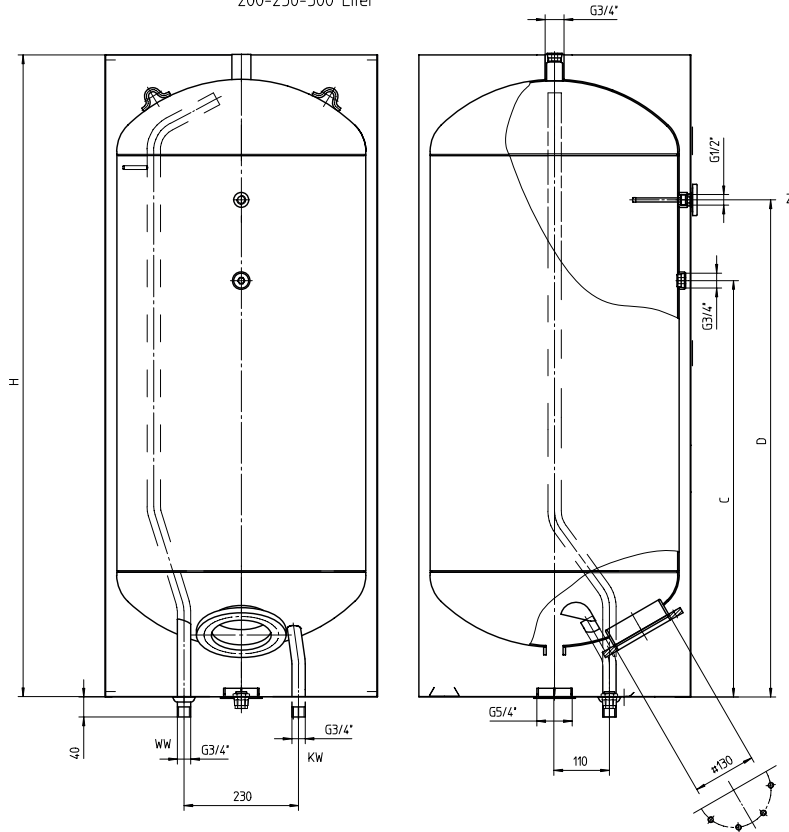

120 Liter

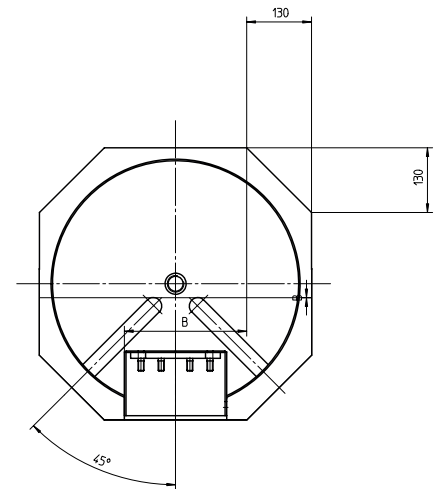
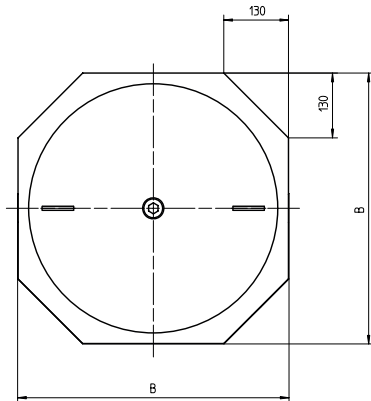
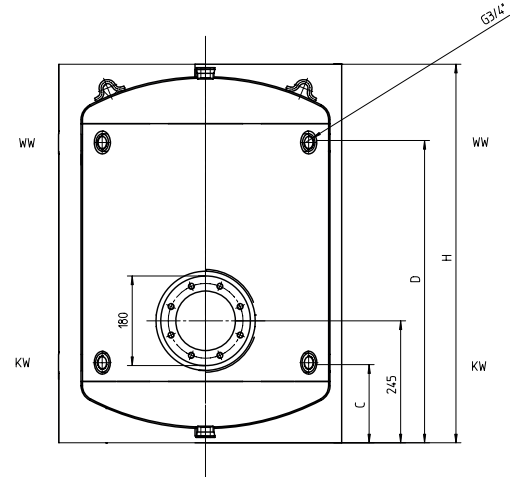

Type	Inhalt Liter	Abmessungen in mm				Leergewicht in kg	Bereitschafts- energieverbrauch kWh/24h	Warmhalte- verlust W	Energieeffizienz- klasse
		B	H	C	D				
SSP 120	120	545	760	160	603	67	1,6	62	C
SSP 200	200	545	1290	836	998	83	1,8	85	C
SSP 250	250	545	1545	986	1180	106	2,3	99	C
SSP 300	300	545	1730	1103	1323	115	2,8	113	C