

Inclined pressure reducing valves



533..H series



01252/15 GB
replaces 01252/13GB



Function

Pressure reducing valves are installed in residential water systems to reduce and stabilise inlet pressure from the water supply network which is generally too high and variable for domestic systems to work properly.

The 533..H series was designed for small systems, such as apartments, and to protect water storages, where size and lack of noise are important aspects.

This specific series of pressure reducing valves is certified according to the EN 1567 standard for operating with inlet water temperatures of up to 80°C.



Product range

5330..H series	Inclined pressure reducing valve	_____	sizes DN 15 (1/2") and DN 20 (3/4")
5331..H series	Inclined pressure reducing valve	_____	sizes DN 15 (Ø 22 x 3/4")
5332..H series	Inclined pressure reducing valve with pressure gauge	_____	sizes DN 15 (1/2"), DN 20 (3/4") and DN 20 (1")
5332..H LTC series	Inclined pressure reducing valve with pressure gauge	_____	sizes DN 15 (1/2"), DN 20 (3/4") and DN 20 (1")
5334..H series	Inclined pressure reducing valve with pressure gauge connection	_____	sizes DN 15 (1/2"), DN 20 (3/4") and DN 20 (1")
5334..H LTC series	Inclined pressure reducing valve with pressure gauge connection	_____	sizes DN 15 (1/2"), DN 20 (3/4") and DN 20 (1")
5336..H series	Inclined pressure reducing valve	_____	sizes DN 15 (Ø 15) and DN 20 (Ø 22)
5337..H series	Inclined pressure reducing valve with pressure gauge connection	_____	sizes DN 15 (Ø 15), DN 20 (Ø 22) and DN 20 (Ø 28)
5338..H series	Inclined pressure reducing valve with pressure gauge	_____	sizes DN 15 (Ø 15), DN 20 (Ø 22) and DN 20 (Ø 28)

Caratteristiche tecniche

Materials

Body:	
- 5330..H, 5332..H and 5334..H series:	brass
- 5332..H LTC and 5334..H LTC series:	EN 12165 CW617N, chrome plated dezincification resistant alloy CR
- 5336..H, 5337..H and 5338..H series:	EN 12165 CW602N, chrome plated dezincification resistant alloy CR
- 5331..H series:	EN 12165 CW602N dezincification resistant alloy CR
Cover:	PA6G30
Control stem:	stainless steel EN 10088-3 (AISI 303)
Spring:	stainless steel EN 10270-1
Cartridge:	PPSG40
Internal component:	PSU
Obturator support:	dezincification resistant alloy CR EN 12164 CW724R
Diaphragm:	EPDM
Seals:	EPDM
Strainer:	stainless steel EN 10088-2 (AISI 304)

Performance

Maximum upstream pressure:	16 bar
Downstream pressure setting range:	1-5,5 bar
Factory setting:	3 bar
	(5331..H series) 3,5 bar
Maximum working temperature:	80°C
Pressure gauge scale:	0-10 bar
Medium:	water
Certification:	EN 1567
Acoustic group:	II (DN 15)

Connections

Main connections:	
- 5330..H:	1/2" and 3/4" F (ISO 228-1)
- 5331..H:	3/4" F (ISO 228-1) with nut x Ø 22 for copper pipe
- 5332..H:	1/2", 1" F (ISO 228-1)
- 5332..H LTC:	1/2", 1" F (ISO 228-1)
- 5334..H:	1/2", 1" F (ISO 228-1)
- 5334..H LTC:	1/2", 1" F (ISO 228-1)
- 5336..H:	Ø15 and Ø 22 for copper pipe
- 5337..H:	Ø15 and Ø 28 for copper pipe
- 5338..H:	Ø15 and Ø 28 for copper pipe

Pressure gauge connection: 1/4" F (ISO 228-1)

Dimensions

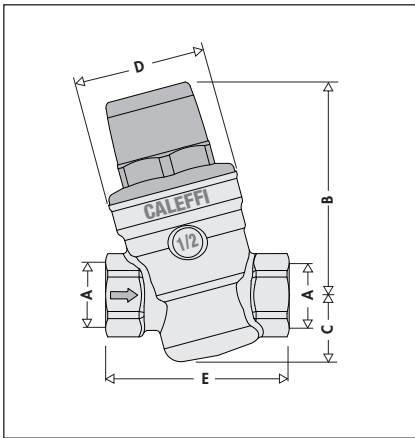

Code	DN	A	B	C	D	E	Mass (kg)
533041H	15	1/2"	74,5	23	∅ 46	64	0,39
533051H	20	3/4"	74,5	23	∅ 46	66	0,41

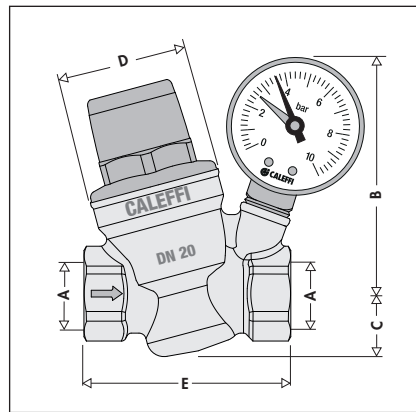

Code	DN	A	B	C	D	E	Mass (kg)
533241H ITC	15	1/2"	86	22	∅ 46	70	0,46
533251H ITC	20	3/4"	86	22	∅ 46	72	0,47
533261H ITC	20	1"	86	22	∅ 46	87	0,62

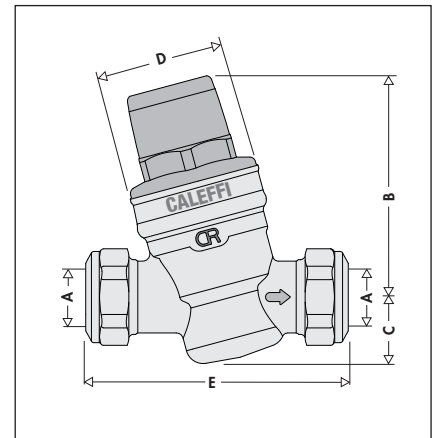

Code	DN	A	B	C	D	E	Mass (kg)
533641H	15	∅ 15	74,5	23	∅ 46	84	0,41
533651H	20	∅ 22	74,5	23	∅ 46	94	0,45

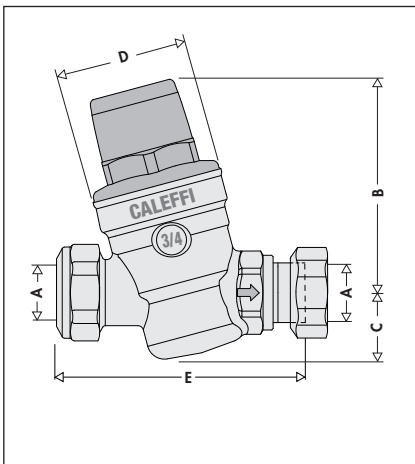

Code	DN	A	B	C	D	E	Mass (kg)
533159H	15	∅ 22	74,5	23	∅ 46	84,5	0,46

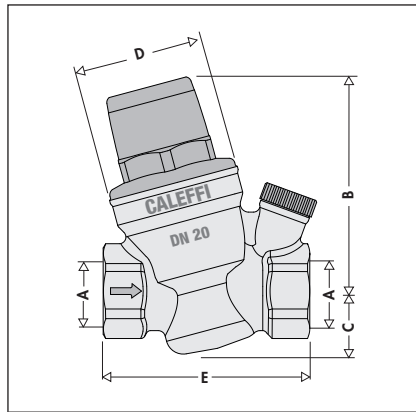

Code	DN	A	B	C	D	E	Mass (kg)
533441H	15	1/2"	74,5	22	∅ 46	70	0,40
533451H	20	3/4"	74,5	22	∅ 46	72	0,41
533461H	20	1"	74,5	22	∅ 46	87	0,56

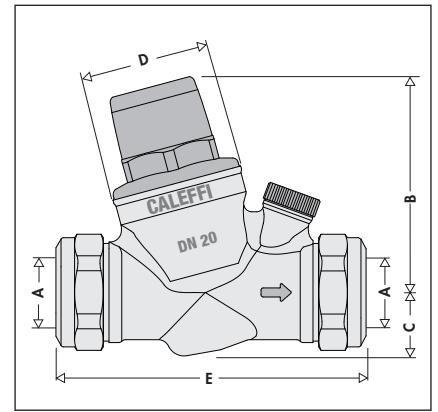

Code	DN	A	B	C	D	E	Mass (kg)
533741H	15	∅ 15	74,5	22	∅ 46	100	0,41
533751H	20	∅ 22	74,5	22	∅ 46	109	0,46
533761H	20	∅ 28	74,5	22	∅ 46	115	0,56

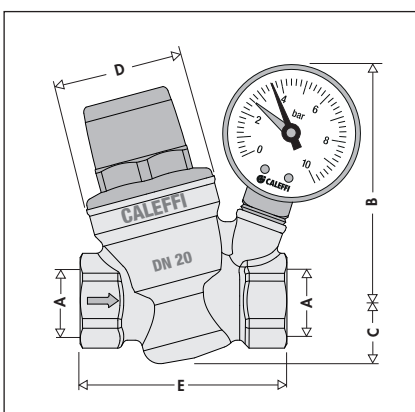

Code	DN	A	B	C	D	E	Mass (kg)
533241H	15	1/2"	86	22	∅ 46	70	0,46
533251H	20	3/4"	86	22	∅ 46	72	0,47
533261H	20	1"	86	22	∅ 46	87	0,62

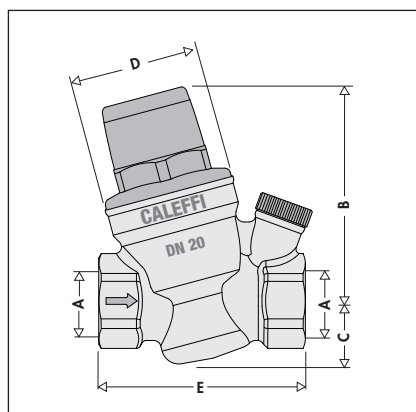

Code	DN	A	B	C	D	E	Mass (kg)
533441H ITC	15	1/2"	74,5	22	∅ 46	70	0,40
533451H ITC	20	3/4"	74,5	22	∅ 46	72	0,41
533461H ITC	20	1"	74,5	22	∅ 46	87	0,56

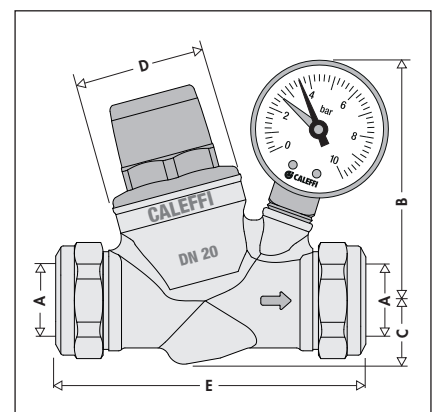

Code	DN	A	B	C	D	E	Mass (kg)
533841H	15	∅ 15	86	22	∅ 46	100	0,50
533851H	20	∅ 22	86	22	∅ 46	109	0,52
533861H	20	∅ 28	86	22	∅ 46	115	0,61

Operating principle

The operation of the pressure reducing valve is based on the balance between two opposing forces:

- 1 the thrust of the spring to open the flow passage cross section.
- 2 the thrust of the diaphragm to close the flow passage cross section.

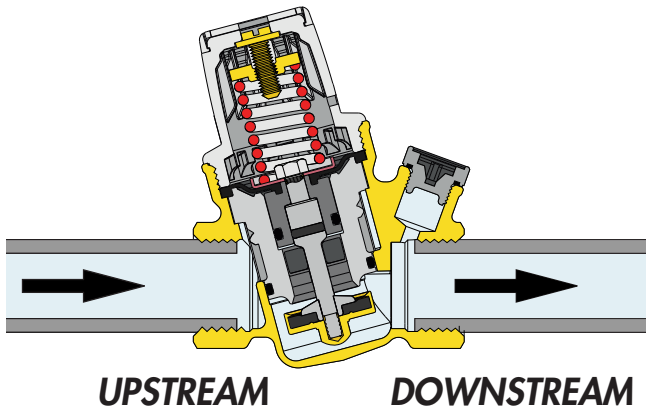

Operation with water flow

When a draw-off outlet is opened, the force of the spring prevails over that of the diaphragm; the obturator moves downwards, thereby opening the valve to the flow of water. The greater the demand for water the lower the pressure under the diaphragm, resulting in a greater flow of water through the passage cross section..

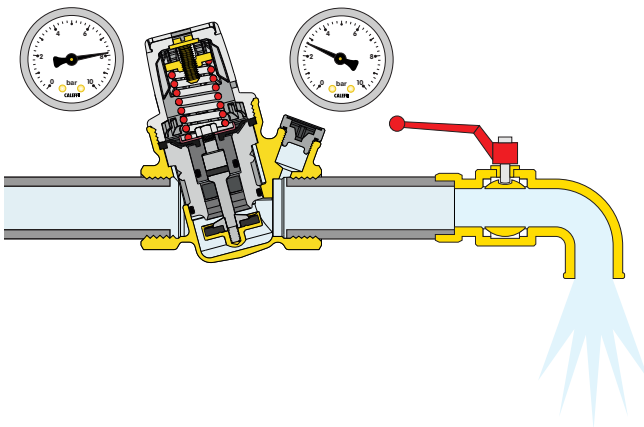

Operation without water flow

When the draw-off outlet is closed, the downstream pressure rises and pushes the diaphragm upwards. As a result, the obturator closes the passage cross section to the flow of water and keeps the pressure constant at the setting value. The slightest difference in favour of the force exercised by the diaphragm over that of the spring causes the device to close.

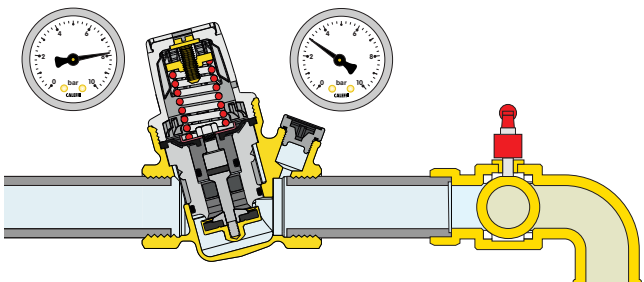

Construction details

Contoured diaphragm

The diaphragm was designed with a special shape to allow for accurate regulation in relation to changes in the downstream pressure. This design feature also extends the valve life as the diaphragm is more resistant to sudden pressure changes and to wear.

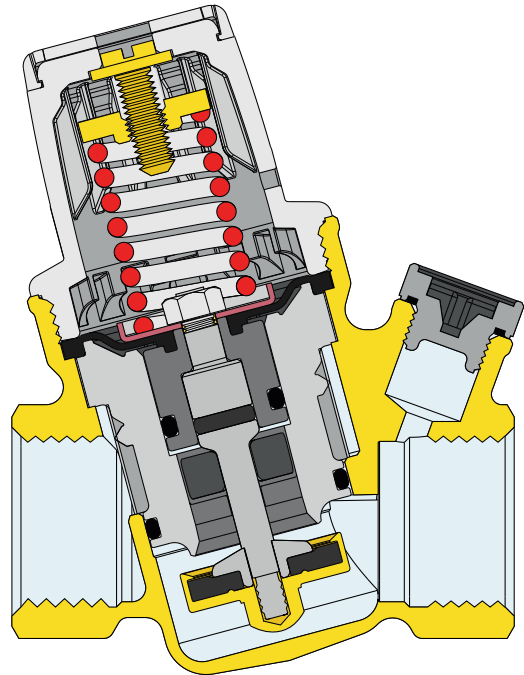

Non-stick materials

The central support ①, which contains the moving parts is made of a plastic material with a low coefficient of adhesion. This solution reduces the potential build-up of scale deposits, the main cause of malfunctions.

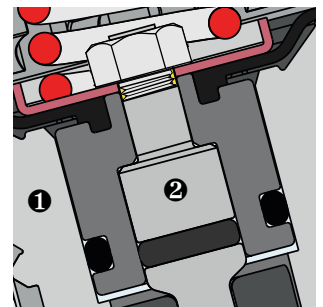

Stainless steel stem

The stainless steel stem ② helps to minimise the typical problems linked to the use of hard and aggressive water.

Removable cartridge

The cartridges mounted on 533...H series pressure reducing valves can be removed for periodic cleaning and maintenance.

Compact dimensions

The "inclined" design guarantees compact dimensions making the 533...H series reducing valves easy to fit, especially in domestic systems.

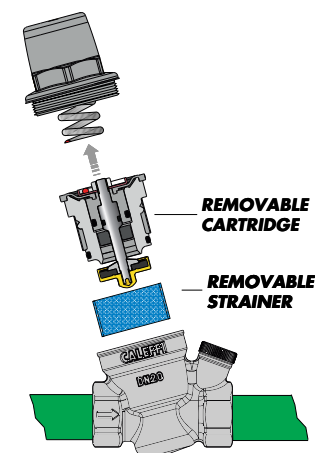

Certifications

The pressure reducing valves are certified according to the EN 1567 standard, making them suitable for use with hot water up to 80°C. Moreover, depending on the model, they comply with WRAS specifications (United Kingdom) and ACS specifications (France).

Hydraulic characteristics

Diagram 1 (Water velocity)

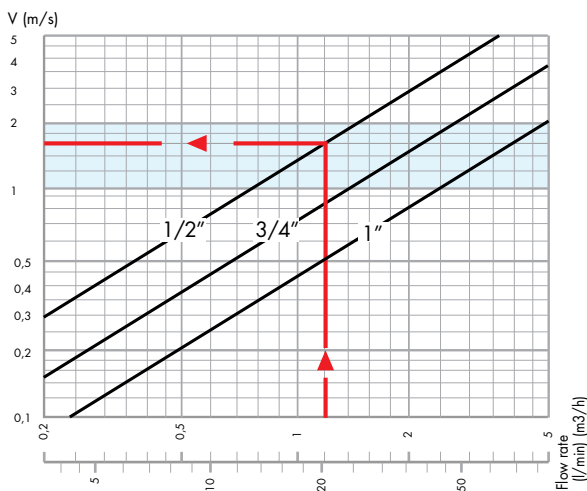
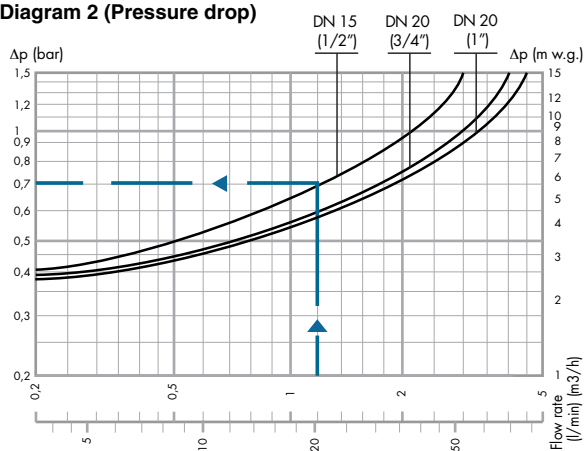

Diagram 2 (Pressure drop)



Reference values: Upstream pressure = 8 bar
Downstream pressure = 3 bar

Sizing the valve

NOTE: the following criterion makes it possible to size the pressure reducing valves by using a fast method of calculating the design flow rate. For a detailed sizing of the domestic water network with design flow rate calculation, please refer to applicable national regulations.

The flow rates of commonly used appliances in hydraulic and domestic water systems are indicated below to facilitate selection of the correct valve diameter:

Table of typical flow rates

Bathtub, kitchen sink, dishwasher	12 l/min
Shower	9 l/min
Washbasin, bidet, washing machine, WC with cistern	6 l/min

The simultaneous-use factor must be taken into account to avoid selecting a valve or pipes that are too large.

Basically, the fewer people using the system, the lower the percentage of appliances being used at the same time.

Table of simultaneous-use factor values (%)

No. of appliances	Residential %	Community %	No. of appliances	Residential %	Community %	No. of appliances	Residential %	Community %
5	54	64,5	35	23,2	30	80	16,5	22
10	41	49,5	40	21,5	28	90	16	21,5
15	35	43,5	45	20,5	27	100	15,5	20,5
20	29	37	50	19,5	26	150	14	18,5
25	27,5	34,5	60	18	24	200	13	17,5
30	24,5	32	70	17	23	300	12,5	16,5

The following steps are necessary for selecting the correct dimensions:

- The total flow rate is calculated from the number and type of appliances present by taking the sum of the individual flow rates.

Example:

One household with 1 bathroom

1 bidet	G = 6 l/min
1 shower	G = 9 l/min
1 wash basin	G = 6 l/min
1 wc with cistern	G = 6 l/min
1 kitchen sink	G = 12 l/min
1 washing machine	G = 12 l/min

$$G_{tot} = 51 \text{ l/min}$$

$$\text{No. of appliances} = 6$$

- The design flow rate is calculated from the table of coefficients of simultaneity (using that for 10 appliances).

Example:

$$G_{pr} = G_{tot} \cdot \% = 51 \cdot 41 \% = 21 \text{ l/min}$$

It is advisable to limit the flow velocity within 1 to 2 metres per second when calculating the correct valve size.

This will prevent the occurrence of noise in the pipes and rapid wear of appliances.

- The correct diameter of the reducing valve is taken from diagram 1 based on the design flow rate, taking into account an ideal flow velocity of between 1 and 2 m/s (blue band).

Example:

for $G_{ds} = 21 \text{ l/min}$ select diameter 1/2"

(see indications on diagram 1)

- The pressure drop is taken from diagram 2 again on the basis of where the design flow rate intersects the curve for the relative diameter already selected (the downstream pressure falls by an amount equal to the pressure drop, with respect to the set pressure at no flow condition).

Example:

for $G_{pr} = 21 \text{ l/min}$ 1/2" $\Delta p = 0,7 \text{ bar}$

(see indications on diagram 2)

Recommended flow rates

For an average flow velocity of 2 m/s, the maximum flow rates for each diameter, according to EN 1567, are as follows:

Ø	DN 15 (1/2" - Ø 15)	DN 20 (3/4" - 1" - Ø 22 - Ø 28)
G (m³/h)	1,27	2,27
G (l/min)	21,16	37,83

Setting

The device can be set by acting on the screw on top of the plastic cover. Turn it clockwise to increase the pressure and anticlockwise to decrease it.

Adjust until the correct pressure appears on the pressure gauge. 533...H series pressure reducing valves are factory set to 3 bar. (3,5 bar for 5331H series).

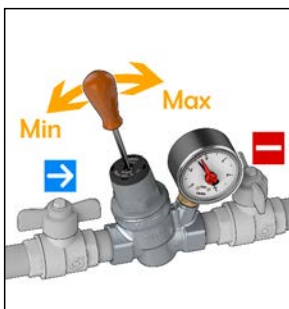

Reccomendation for installation

1. Installation below ground

Installing pressure reducing valves below ground is not recommended, for three reasons:

- there is a risk of the reducing valve being damaged by frost
- inspection and maintenance is difficult
- reading the pressure gauge is difficult.

2. Water hammer

This is one of the main causes of faults in pressure educing valves. It is advisable to fit special devices to absorb water hammer effects when installing pressure reducing valves in systems at risk.

Troubleshooting

Certain types of faults, which are generally due to improper design of the system, are often wrongly attributed to the pressure reducing valve. The most frequent cases are the following:

1. Increased downstream pressure in the presence of a water heater

This problem is due to overheating of the water caused by the water heater.

The pressure is not relieved because the pressure reducing valve is rightly closed.

The solution is to install an expansion vessel (between the water heater and the reducing valve) to "absorb" the pressure increase.

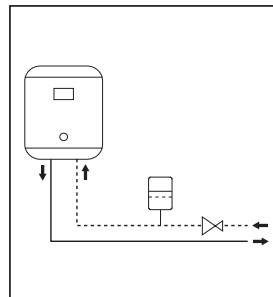

2. The pressure reducing valve does not maintain its setting value

In most cases this is caused by impurities that deposit on the valve's seal seats causing leakage and a resulting increase in downstream pressure.

The preventive solution is to mount a strainer upstream of the reducing valve and, subsequently, to maintain and clean the removable cartridge.

Application diagram

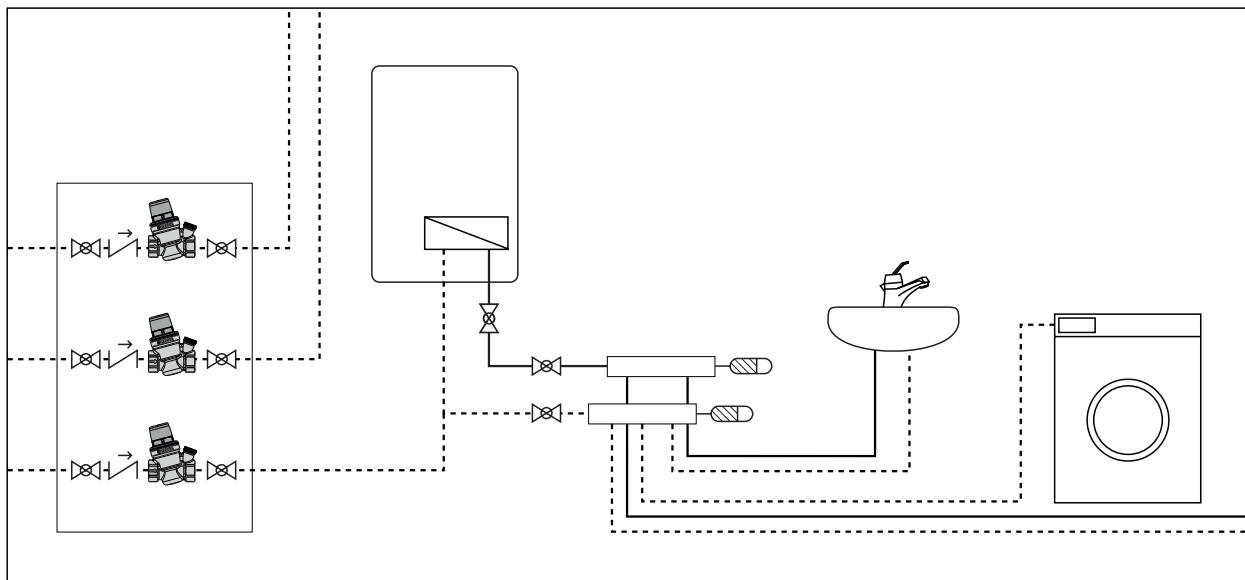

SPECIFICATION SUMMARY

5330..H series

Inclined pressure reducing valve. Size DN 15 (DN 15 and DN 20). Threaded connections 1/2" (1/2" and 3/4") F (ISO 228-1). Brass body. Chrome plated. Stainless steel control stem. PA6G30 cover. EPDM diaphragm and seals. Maximum working temperature 80°C. Maximum upstream pressure 16 bar. Downstream pressure setting range from 1 to 5,5 bar. Removable cartridge and strainer for maintenance operations.

5331..H series

Inclined pressure reducing valve. Size DN 15. Threaded connections 3/4" with nut for Ø 15 for copper pipe. Dezincification resistant alloy body. Stainless steel control stem. PA6G30 cover. EPDM diaphragm and seals. Maximum working temperature 80°C. Maximum upstream pressure 16 bar. Downstream pressure setting range from 1 to 5,5 bar. Removable cartridge and strainer for maintenance operations.

5332..H series

Inclined pressure reducing valve with pressure gauge. Size DN 15 (DN 15 and DN 20). Threaded connections 1/2" (from 1/2" to 1") F (ISO 228-1). Pressure gauge connection 1/4" F. Brass body. Chrome plated. Stainless steel control stem. PA6G30 cover. EPDM diaphragm and seals. Maximum working temperature 80°C. Maximum upstream pressure 16 bar. Downstream pressure setting range from 1 to 5,5 bar. Removable cartridge and strainer for maintenance operations.

5332..H LTC series

Inclined pressure reducing valve with pressure gauge. Size DN 15 (DN 15 and DN 20). Threaded connections 1/2" (from 1/2" to 1") F (ISO 228-1). Pressure gauge connection 1/4" F. Dezincification resistant alloy body. Chrome plated. Stainless steel control stem. PA6G30 cover. EPDM diaphragm and seals. Maximum working temperature 80°C. Maximum upstream pressure 16 bar. Downstream pressure setting range from 1 to 5,5 bar. Removable cartridge and strainer for maintenance operations.

5334..H series

Inclined pressure reducing valve with pressure gauge connection. Size DN 15 (DN 15 and DN 20). Threaded connections 1/2" (from 1/2" to 1") F (ISO 228-1). Pressure gauge connection 1/4" F. Brass body. Chrome plated. Stainless steel control stem. PA6G30 cover. EPDM diaphragm and seals. Maximum working temperature 80°C. Maximum upstream pressure 16 bar. Downstream pressure setting range from 1 to 5,5 bar. Removable cartridge and strainer for maintenance operations.

5334..H LTC series

Inclined pressure reducing valve with pressure gauge connection. Size DN 15 (DN 15 and DN 20). Threaded connections 1/2" (from 1/2" to 1") F (ISO 228-1). Pressure gauge connection 1/4" F. Dezincification resistant alloy body. Chrome plated. Stainless steel control stem. PA6G30 cover. EPDM diaphragm and seals. Maximum working temperature 80°C. Maximum upstream pressure 16 bar. Downstream pressure setting range from 1 to 5,5 bar. Removable cartridge and strainer for maintenance operations.

5336..H series

Inclined pressure reducing valve. Size DN 15 (DN 15 and DN 20). Connections Ø 15 (from Ø 15 to Ø 28) for copper pipe. Pressure gauge connection 1/4" F. Dezincification resistant alloy body. Chrome plated. Stainless steel control stem. PA6G30 cover. EPDM diaphragm and seals. Maximum working temperature 80°C. Maximum upstream pressure 16 bar. Downstream pressure setting range from 1 to 5,5 bar. Removable cartridge and strainer for maintenance operations.

5337..H series

Inclined pressure reducing valve with pressure gauge connection. Size DN 15 (DN 15 and DN 20). Connections Ø 15 (from Ø 15 to Ø 28) for copper pipe. Pressure gauge connection 1/4" F. Dezincification resistant alloy body. Chrome plated. Stainless steel control stem. PA6G30 cover. EPDM diaphragm and seals. Maximum working temperature 80°C. Maximum upstream pressure 16 bar. Downstream pressure setting range from 1 to 5,5 bar. Removable cartridge and strainer for maintenance operations.

5338..H series

Inclined pressure reducing valve with pressure gauge. Size DN 15 (DN 15 and DN 20). Connections Ø 15 (from Ø 15 to Ø 28) for copper pipe. Pressure gauge connection 1/4" F. Dezincification resistant alloy body. Chrome plated. Stainless steel control stem. PA6G30 cover. EPDM diaphragm and seals. Maximum working temperature 80°C. Maximum upstream pressure 16 bar. Downstream pressure setting range from 1 to 5,5 bar. Removable cartridge and strainer for maintenance operations.

We reserve the right to change our products and their relevant technical data, contained in this publication, at any time and without prior notice.