

Abgaszubehör

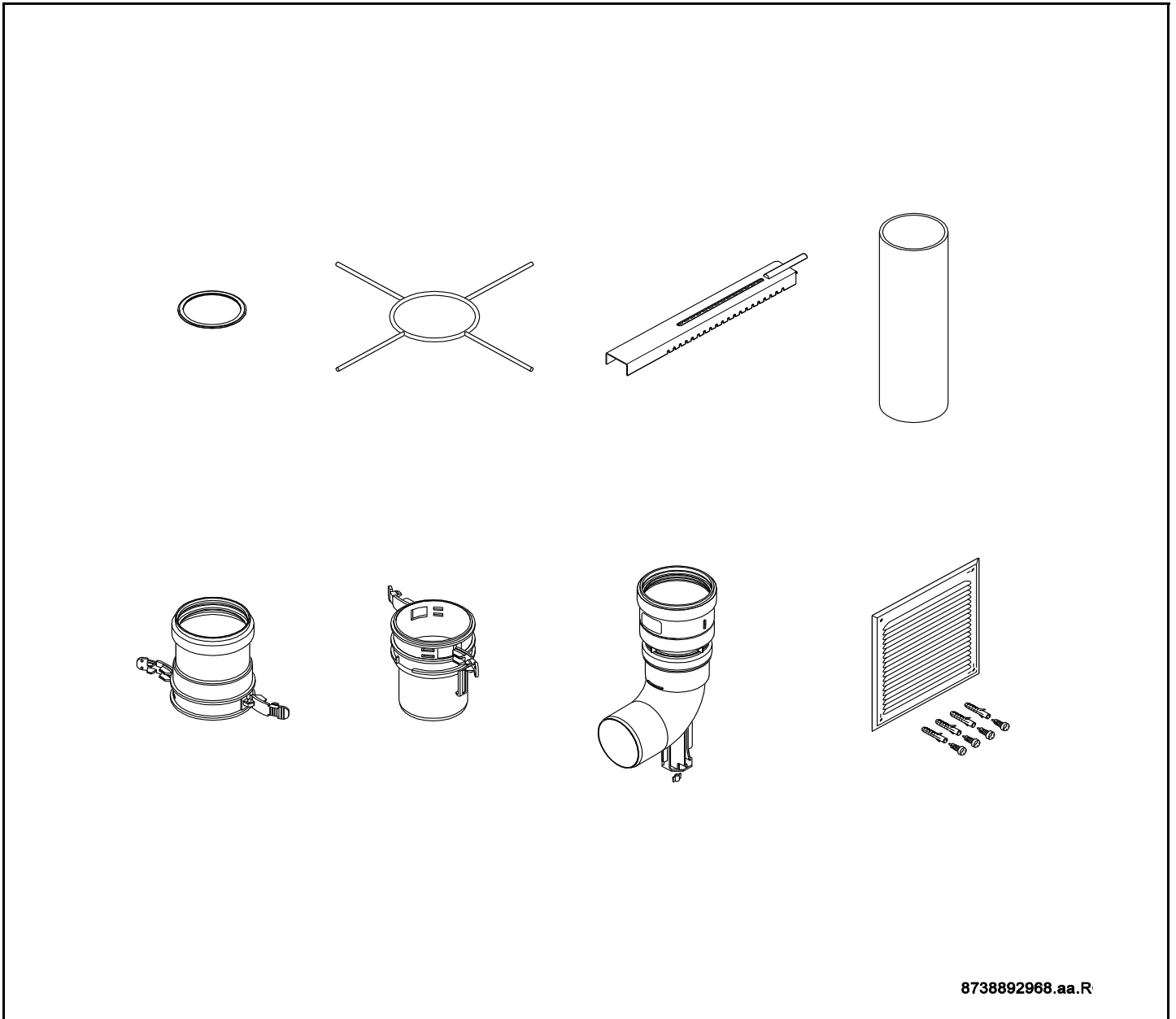

8738892968.aa.R

**Inhaltsverzeichnis
Table of contents****Table de matieres
Indice****Indice
Inhoud**

AZB 523/1	7 719 002 817	5
AZB 614/1	7 719 001 947	6
AZB 665	7 719 001 864	7
AZB 668	7 719 001 867	8
AZB 670	7 719 001 869	9
AZB 673	7 719 001 872	10
AZB1361	7 738 111 165	11
AZB1362	7 738 111 166	12
AZB1363	7 738 111 167	13
AZB1364	7 738 111 168	14
AZB1365	7 738 111 169	15
AZB1366	7 738 111 170	16
AZB1368	7 738 111 172	17
AZB1369	7 738 111 173	18
AZB1371	7 738 111 175	19
AZB1372	7 738 111 176	20
AZB1373	7 738 111 177	21
AZB1374	7 738 111 178	22
AZB1376	7 738 111 180	23
AZB1377	7 738 111 181	24
AZB1378	7 738 111 182	25
AZB1380	7 738 111 184	26
AZB1381	7 738 111 185	27
AZB1382	7 738 111 186	28
Erweitpaket D60	7 738 111 211	29
Erweitpaket D80	7 738 111 207	30
Erweitpaket D100	7 738 111 209	31
Flexl Erwtrg DN60 5m	7 738 111 189	32
Flexltg 60mm 12,5m	7 738 111 188	33
Gbaustz Schacht DN60	7 738 111 190	34
Grdbstz WH/WS 60-100	7 738 111 193	35
Grdbtz DO rot 60-100	7 738 111 192	36
Grdbtz DO sw DN60-10	7 738 111 191	37
Grdpaket flex D60	7 738 111 210	38
Grdpaket flex D80	7 738 111 206	39
Grdpaket flex D100	7 738 111 208	40
Horiz Abgfrg D60/100	7 738 111 213	41

Ersatzteilliste
Spare parts list
Liste des pièces de rechange
Lista parti di ricambio
Lista de repuestos
Onderdelenlijst

AZB1371 - 7738111175

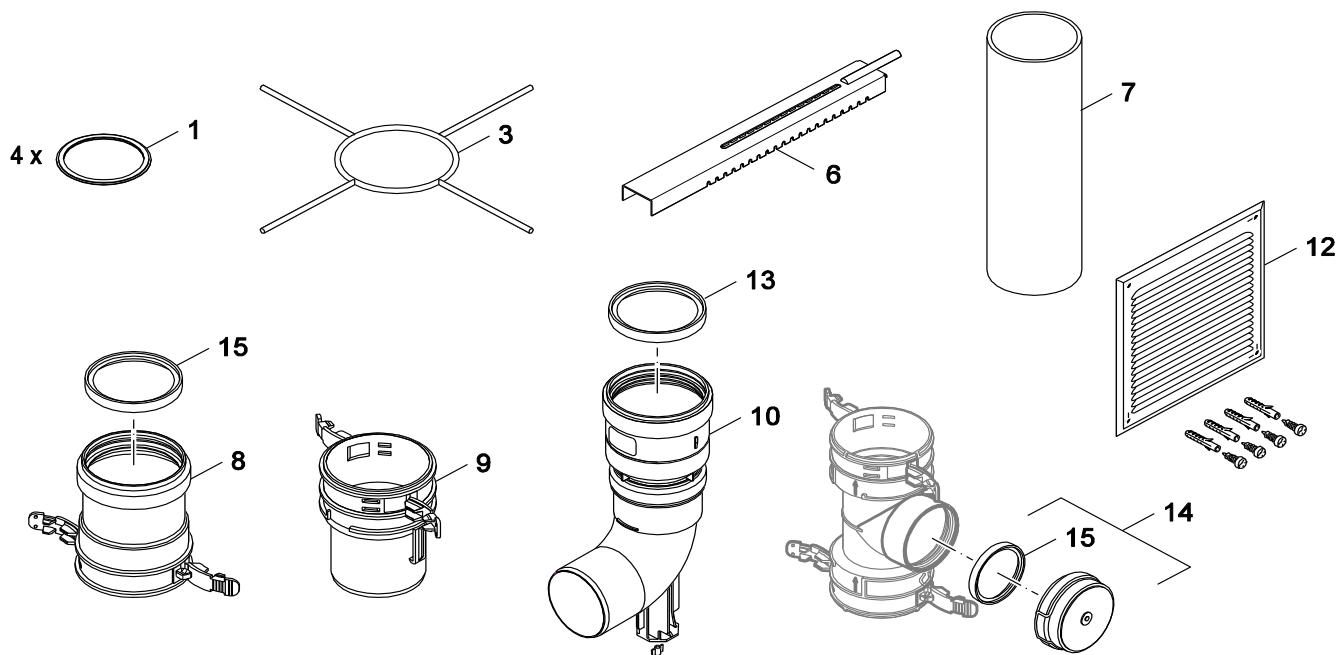

8738892969.aa.F

Pos	Bestell-Nr.	Bezeichnung	Description	Dénomination	Descrizione	Descripción	Benaming	PG
1	8 718 666 490 0	Dichtung D80 flex	Seal inner 80mm flexible	Joint	Guarnizione	Junta interior 80mm	Packingring	27
3	8 718 666 489 0	Halter Schacht D80	Elbow bracket funnel	Coude d'appui buse cheminee	Gomiot di supporto fissaggio ciminiera	Codo soporte fijacion chimenea	Steenbochten bevestiging shouw	40
6	8 718 003 749 0	Auflageschiene	Flue Support Channel	Rail	Rotaia	Rail	Montagebeugel	
7	8 715 504 535 0	Endrohr DN80x500LG	End pipe DN80x500LG	Tuyaux de final DN80x500LG	Tubo la finale DN80x500LG	Tubo el final DN80x500LG	VERLENGBLUIS 500MM UIT AZB 665/12 (ZWART)	23
8	8 718 666 487 0	Muffe oben D80	Connecting pipe above	Tube de raccordement en haut	Raccordo in alto	Tubo agua alto	VERBINDINGSTUK boven bocht fle	30
9	8 718 666 492 0	Muffe unten D80	Connecting pipe below	Tube de raccordement en bas	Raccordo di sotto	Tubo agua bajo	VERBINDINGSTUK beneden	29
10	8 718 666 493 0	Stützbogen D80	Elbow bracket D80	Coude d'appui D80	Gomito di supporto D80	Codo soporte D80	Steenbochten D80	33
12	8 718 007 345 0	Lüftungsgitter	Ventilation grid	Grille d'aération	Griglia di aerazione	Rejilla de ventilacion	VERLUCHTINGSROOSTER AZB 665/12	36
13	8 718 223 472 0	Dichtung	Seal	Joint	Guarnizione	Junta	pakking	20
14	8 718 668 272 0	Abdeckung mit Dichtung D80	Elbow bracket coverage with sealing	Coude d'appui protectionavec joint	Gomito di supporto comeratura in guariz	Codo soporte ubierta con junta interior	Steenbochten afdekking met pakkingring	38
15	8 718 668 273 0	Dichtung Verschlussdeckel D80	Seal inner cover	Joint	Guarnizione	Junta interior	Packingring	28

For:

Ersatzteilliste
Spare parts list
Liste des pièces de rechange
Lista parti di ricambio
Lista de repuestos
Onderdelenlijst

Grdpaket flex D100 - 773811208

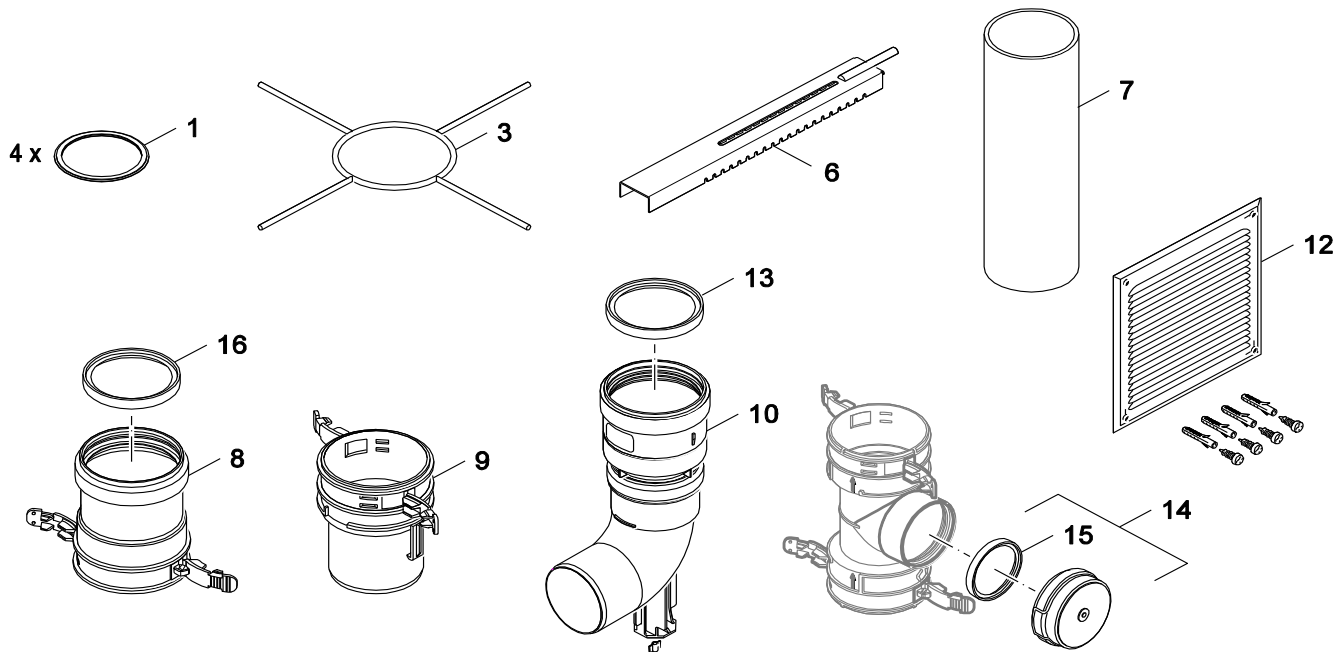

8738893041.aa.F

Pos	Bestell-Nr.	Bezeichnung	Description	Dénomination	Descrizione	Descripción	Benaming	PG
1	8 718 666 509 0	Dichtung D100 flex	Seal inner 100mm flexible	Joint	Guarnizione	Junta interior 100mm	Packingring	28
3	8 718 666 508 0	Halter Schacht D100	Elbow bracket funnel	Coude d'appui buse cheminee	Gomito di supporto fissaggio ciminiera	Codo soporte fijacion chimenea	Steenbochten bevestiging shouw	40
6	8 718 003 749 0	Auflageschiene	Flue Support Channel	Rail	Rotaia	Rail	Montagebeugel	
7	8 715 504 536 0	Verlängerungsrohr	Extension pipe	Tuyaux de rallonge	Prolunga	Tubo extensión	Verlengpijp	28
8	8 718 666 506 0	Muffe oben D100	Connecting pipe above	Tube de raccordement en haut	Raccordo in alto	Tubo agua alto	VERBINDINGSTUK boven bocht fle	31
9	8 718 666 511 0	Muffe unten D100	Connecting pipe below	Tube de raccordement en bas	Raccordo di sotto	Tubo agua bajo	VERBINDINGSTUK beneden	30
10	8 718 666 493 0	Stützbogen D80	Elbow bracket D80	Coude d'appui D80	Gomito di supporto D80	Codo soporte D80	Steenbochten D80	33
12	8 718 007 345 0	Lüftungsgitter	Ventilation grid	Grille d'aération	Griglia di aerazione	Rejilla de ventilacion	VERLUCHTINGSROOSTER AZB 665/12	36
13	8 718 223 472 0	Dichtung	Seal	Joint	Guarnizione	Junta	pakking	20
14	8 718 668 272 0	Abdeckung mit Dichtung D80	Elbow bracket coverage with sealing	Coude d'appui protectionavec joint	Gomito di supporto comeratura in guariz	Codo soporte ubierta con junta interior	Steenbochten afdekking met pakkingring	38
15	8 718 668 273 0	Dichtung Verschlussdeckel D80	Seal inner cover	Joint	Guarnizione	Junta interior	Packingring	28
16	8 718 668 274 0	Dichtung Verschlussdeckel D100	Seal	Joint	Guarnizione	Junta interior	Packingring	28

For:

**Bosch Thermotechnik GmbH
D-35576 Wetzlar / Germany**